

Low Noise Type Pilot Operated Relief Valve

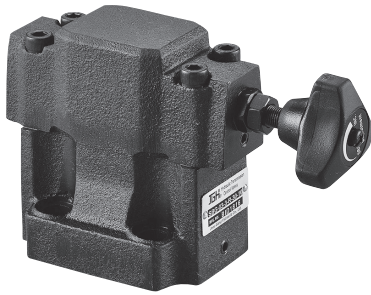

閥類型符號 SYMBOL
SBG- ※

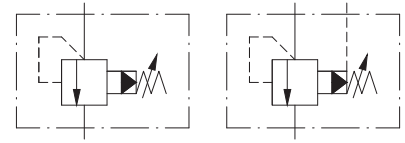

遠程控制
REMOTE CONTROL

規格說明 SPECIFICATION

型式 MODEL	最高使用壓力 MAX. OPERATING PRESSURE (kgf/cm ²)	調壓範圍 PRESSURE ADJ. RANGE kgf/cm ²	最大流量 MAX. FLOW L/min	重量 WEIGHT kg
SBG-03	250	0 : 7-35	100	4.1
SBG-06		1 : 7-70 2 : 7-140	200	5.1
SBG-10		3 : 7-210	400	6.5

型號說明 HOW TO ORDER

SB G - 06 - 3 - R - 30 - 10

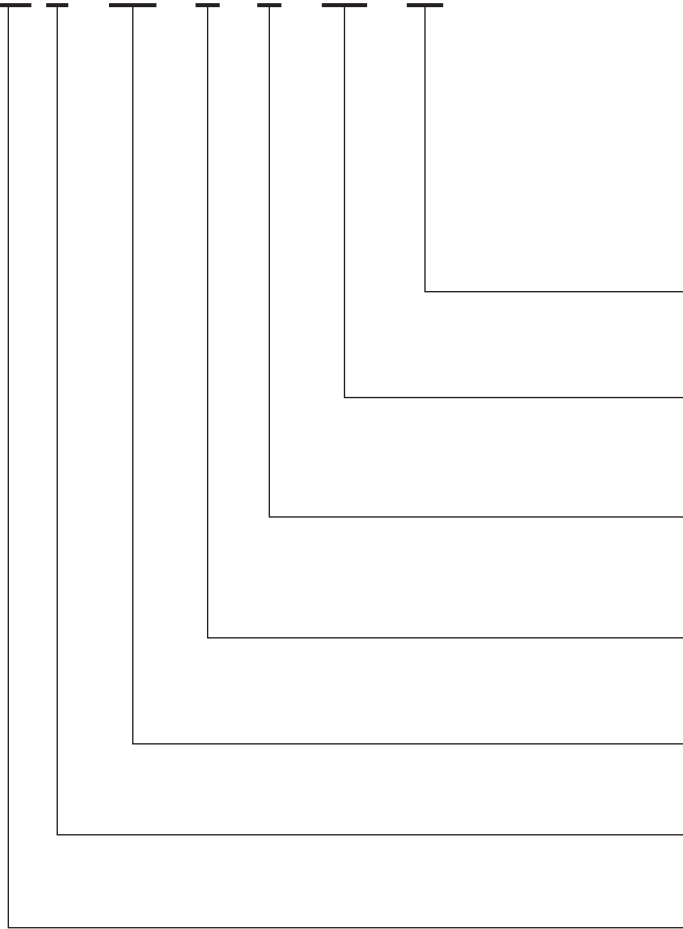

附屬品 ATTACHMENT

型式 MODEL	安裝螺絲 SOC HOL CAP SCREW	安裝扭矩 MOUNTING TORQUE N·m
SBG-03	M12 x 40L...4pcs	104~127
SBG-06	M16 x 50L...4pcs	253~310
SBG-10	M20 x 65L...4pcs	493~603

設計編號 DESIGN NUMBER

調桿型式 ADJUSTMENT TYPE
30 : 標準型 STANDARD TYPE
32 : T型推環直結式 THRUST RING LINK TYPE

把手方向 DIRECTION OF KNOB
R : 右(P口側標準型) RIGHT (P PORT SIDE STANDARD)
L : 左(T口側) LEFT (T PORT SIDE)

調壓範圍 PRESSURE ADJUSTING RANGE
0 : 7-35 kgf/cm² 1 : 7-70 kgf/cm²
2 : 7-140 kgf/cm² 3 : 7-210 kgf/cm²

閥規格 VALVE SIZE
03 : 3/8" 06 : 3/4" 10 : 1-1/4"

安裝型式 MOUNTING
G : 板式安裝 SUB-PLATE MOUNTING

系列編號 SERIES NUMBER

單位 UNIT : mm

安裝尺寸 INSTALLATION DIMENSIONS

SBG-03~10-R

通用底板尺寸
 APPLICATIVE
 SUB-PLATE DIMENSIONS
SBG-03 (MA - 02 - 1)
SBG-06 (MA - 02 - 2)
SBG-10 (MA - 02 - 3)
 (詳見 E01-01 Page E01-01)

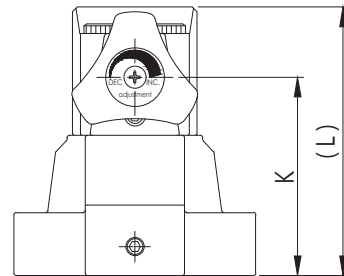
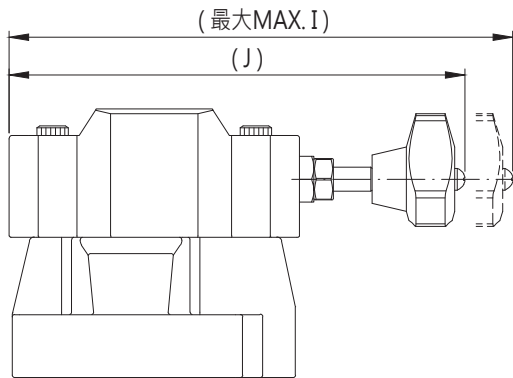
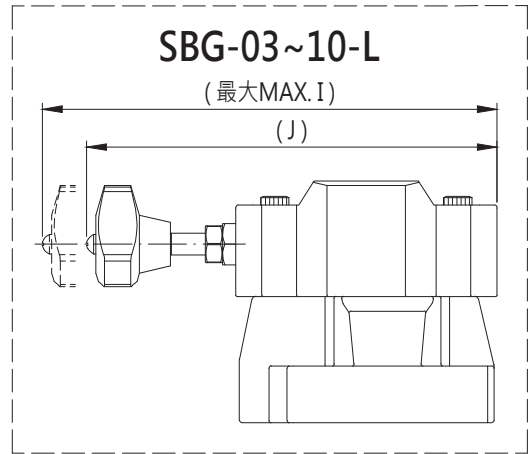
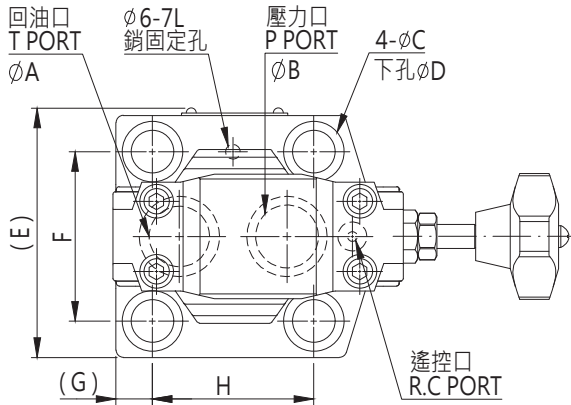

型式 MODEL	A	B	C	D	E	F
SBG-03	15	15	20	13	81	53.8
SBG-06	25	25	25	17.5	103	70
SBG-10	30	30	31.5	21.5	117	82.6

型式 MODEL	G	H	I	J	K	L
SBG-03	33.7	53.8	188.5	172.5	82	111
SBG-06	15	66.7	188.5	172.5	82	111
SBG-10	17	88.9	208.5	192.5	82	111