

## Low Noise Type Proportional Control Relief Valve

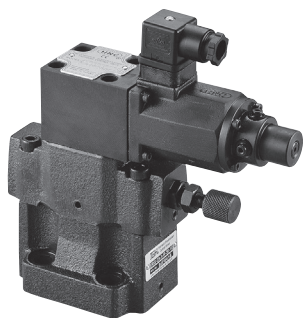

閥類型符號 SYMBOL  
ERG- ※

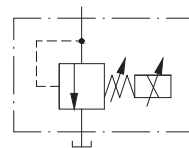

## 規格說明

## SPECIFICATION

型式 MODEL	最高使用壓力 MAX. OPERATING PRESSURE (kgf/cm <sup>2</sup> )	調壓範圍 PRESSURE ADJ. RANGE kgf/cm <sup>2</sup>	最大流量 MAX. FLOW L/min	重量 WEIGHT kg
ERG-03	210	0 : 7-35	100	3.9
ERG-06		1 : 7-70 2 : 7-140	200	4.9
ERG-10		3 : 7-210	400	6.5

## 型號說明

## HOW TO ORDER

**ER G - 06 - C - 3 - R - 30 - 10**

## 附屬品

## ATTACHMENT

型式 MODEL	安裝螺絲 SOC HOL CAP SCREW	安裝扭矩 MOUNTING TORQUE N·m
ERG-03	M12 x 40L...4pcs	104~127
ERG-06	M16 x 50L...4pcs	253~310
ERG-10	M20 x 65L...4pcs	493~603

設計編號 DESIGN NUMBER

調桿型式 ADJUSTMENT TYPE

30 : 標準型 STANDARD TYPE

32 : T型推環直結式 THRUST RING LINK TYPE

把手方向 DIRECTION OF KNOB

R : 右(P口側標準型) RIGHT (P PORT SIDE STANDARD)

L : 左(T口側) LEFT (T PORT SIDE)

調壓範圍 PRESSURE ADJUSTING RANGE

0 : 7-35 kgf/cm<sup>2</sup>    1 : 7-70 kgf/cm<sup>2</sup>

2 : 7-140 kgf/cm<sup>2</sup>    3 : 7-210 kgf/cm<sup>2</sup>

比例引導式 PROPORTIONAL

C : 140 kgf/cm<sup>2</sup>    H : 210 kgf/cm<sup>2</sup>

閥規格 VALVE SIZE

03 : 3/8"    06 : 3/4"    10 : 1-1/4"

安裝型式 MOUNTING

G : 板式安裝 SUB-PLATE MOUNTING

系列編號 SERIES NUMBER

單位 UNIT : mm

**安裝尺寸** INSTALLATION DIMENSIONS

**ERG-03~10-R-10**

通用底板尺寸

APPLICATIVE

SUB-PLATE DIMENSIONS

**ERG-03 ( MA - 02 - 1 )**

**ERG-06 ( MA - 02 - 2 )**

**ERG-10 ( MA - 02 - 3 )**

(詳見 E01-01 Page E01-01)

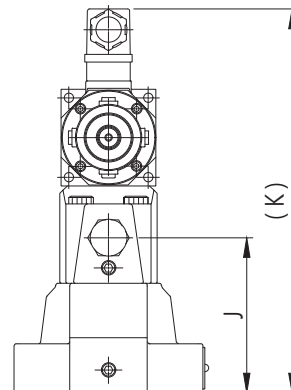
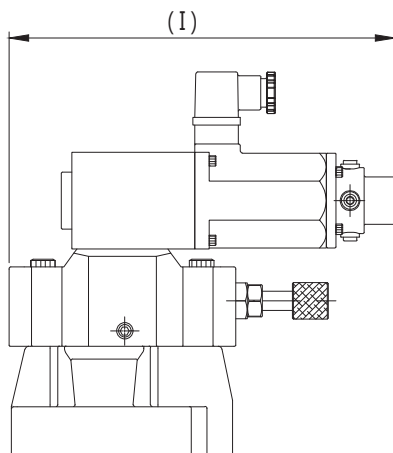
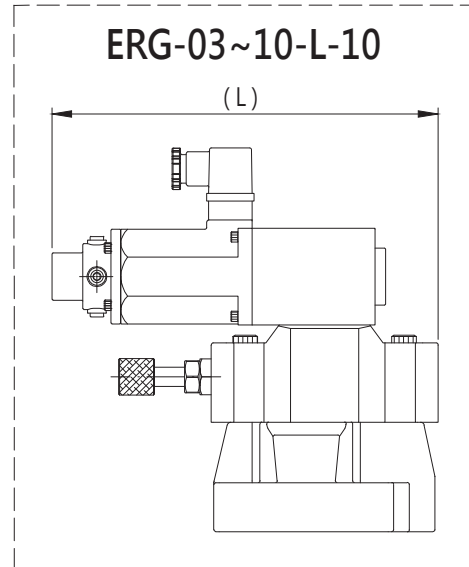
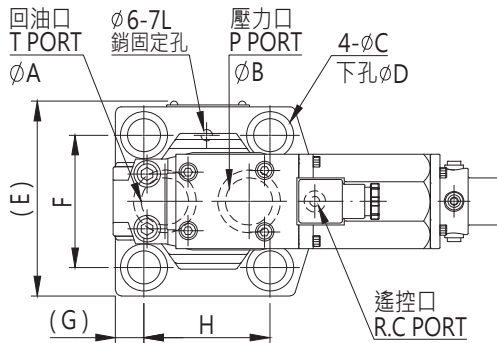

型式 MODEL	A	B	C	D	E	F
ERG-03-R-10	15	15	20	13	81	53.8
ERG-06-R-10	25	25	25	17.5	103	70
ERG-10-R-10	30	30	31.5	21.5	117	82.6

型式 MODEL	G	H	I	J	K	L
ERG-03-R-10	33.7	53.8	204.3	82	203	204.3
ERG-06-R-10	15	66.7	204.3	82	203	204.3
ERG-10-R-10	17	88.9	224.2	82	203	211.8