

## HC Type Pressure Control Valve

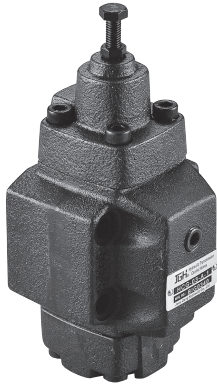

### 規格說明

### SPECIFICATION

型式 MODEL		最高使用壓力 MAX. OPERATING PRESSURE kgf/cm <sup>2</sup>	最大流量 MAX. FLOW L/min	調壓範圍 PRESSURE ADJ. RANGE kgf/cm <sup>2</sup>	重量 WEIGHT kg	
板式安裝 SUB-PLATE MOUNTING	管式安裝 THREADED CONNECTIONS					
HCG-03	HCT-03	250	50	A : 18-35 B : 35-70 C : 70-140	5	4.3
HCG-06	HCT-06		125		8	7.6
HCG-10	HCT-10		250		14	15.8

### 型號說明

### HOW TO ORDER

**HC G - 06 - A - 4**

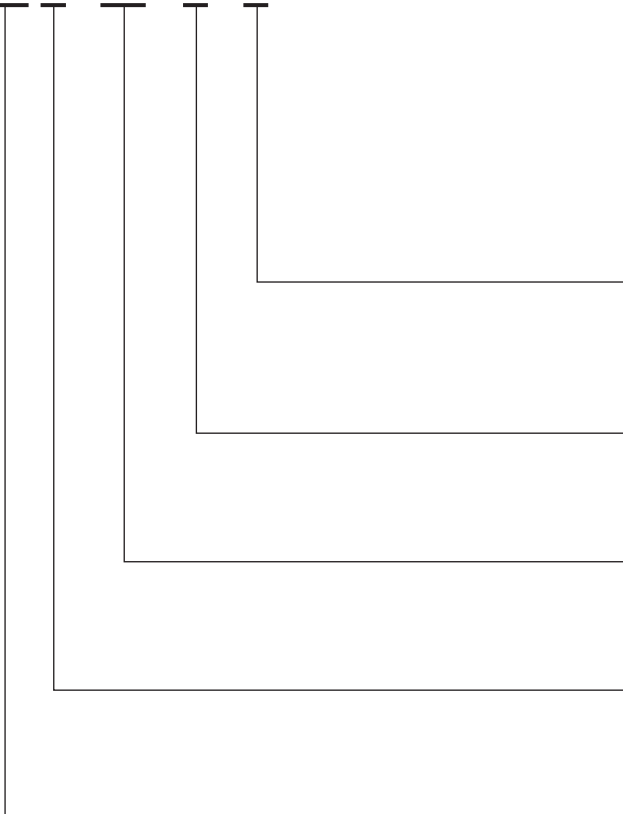

### 附屬品

### ATTACHMENT

型式 MODEL	安裝螺絲 SOC HOL CAP SCREW	安裝扭矩 MOUNTING TORQUE N·m
HCG-03	M10 x 70L...4pcs	60~74
HCG-06	M10 x 80L...4pcs	
HCG-10	M10 x 95L...6pcs	

#### 控油方式 PILOT AND DRAIN TYPE

- 1 : 內部引導內部洩油 INTERNAL PILOT & DRAIN
- 2 : 內部引導外部洩油 INTERNAL PILOT EXTERNAL DRAIN
- 3 : 外部引導外部洩油 EXTERNAL PILOT & DRAIN
- 4 : 外部引導內部洩油 EXTERNAL PILOT INTERNAL DRAIN

#### 調壓範圍 PRESSURE ADJUSTING RANGE

- A : 18-35 kgf/cm<sup>2</sup>    B : 35-70 kgf/cm<sup>2</sup>
- C : 70-140 kgf/cm<sup>2</sup>

#### 閥規格 VALVE SIZE

- 03 : 3/8"    06 : 3/4"    10 : 1-1/4"

#### 安裝型式 MOUNTING

- G : 板式安裝 SUB-PLATE MOUNTING
- T : 管式安裝 THREADED CONNECTIONS

#### 系列編號 SERIES NUMBER

閥型式 VALVE TYPE	低壓溢流閥 TYPE 1. LOW PRESSURE RELIEF VALVE	順序閥 TYPE 2. SEQUENCE VALVE	順序閥 TYPE 3. SEQUENCE VALVE	卸載閥 TYPE 4. UNLOADING RELIEF VALVE
引導洩油型式 PILOT DRAIN TYPE	內部引導內部洩油 INTERNAL PILOT INTERNAL DRAIN	內部引導外部洩油 INTERNAL PILOT EXTERNAL DRAIN	外部引導外部洩油 EXTERNAL PILOT EXTERNAL DRAIN	外部引導內部洩油 EXTERNAL PILOT INTERNAL DRAIN
示意圖 ACTIVITY DIAGRAM				
液壓符號 SYMBOL				

### 測試條件 PERFORMANCE CURVES

測試油黏度 TEST FLUID VISCOSITY : 35cSt

測試油溫度 TEST TEMPERATURE : 50°C

自由流壓力降特性 PRESSURE DROP FOR FREE FLOW

#### ● HCG, HCT-03

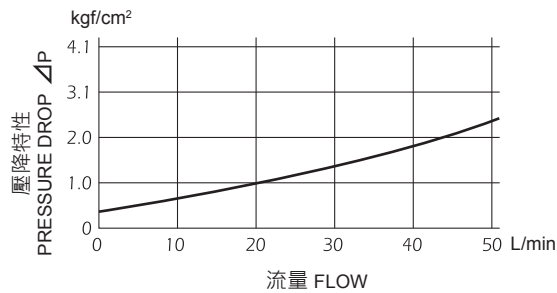

#### ● HCG, HCT-06

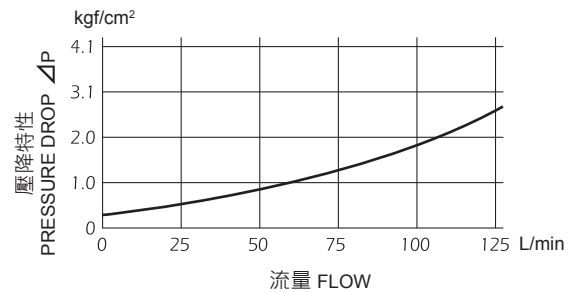

#### ● HCG, HCT-10

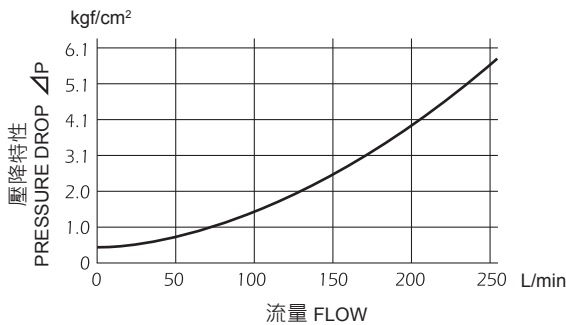

單位 UNIT : mm

**安裝尺寸 INSTALLATION DIMENSIONS**

**HCG-03~10**

型式：外部引導外部洩油  
TYPE : EXTERNAL PILOT & DRAIN

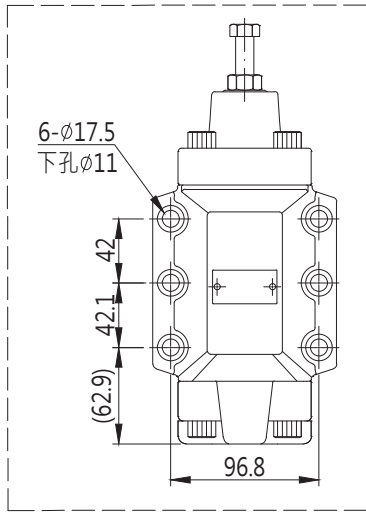

通用底板尺寸  
APPLICATIVE  
SUB-PLATE DIMENSIONS  
**HCG-03 ( MA - 05 - 1 )**  
**HCG-06 ( MA - 05 - 2 )**  
**HCG-10 ( MA - 05 - 3 )**  
(詳見 E01-04 Page E01-04)

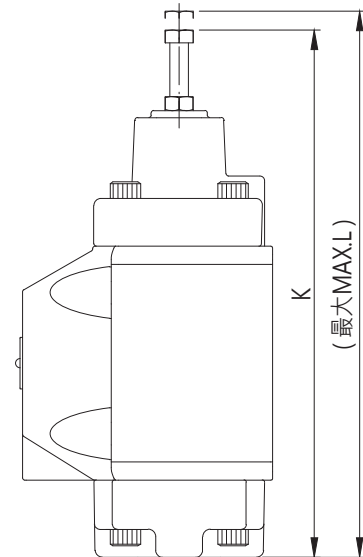
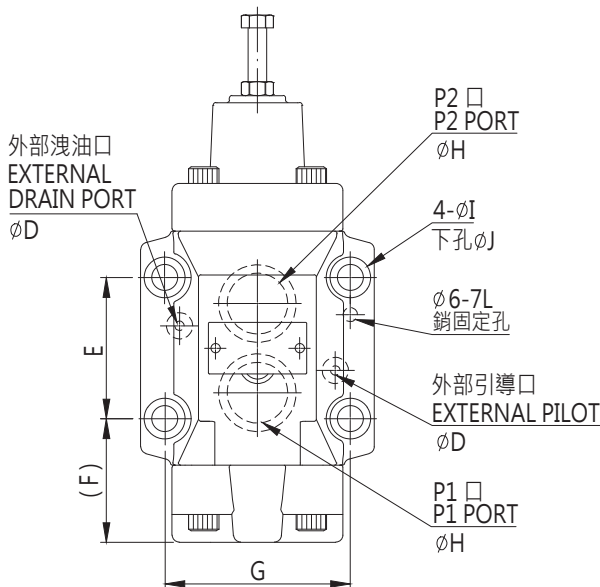
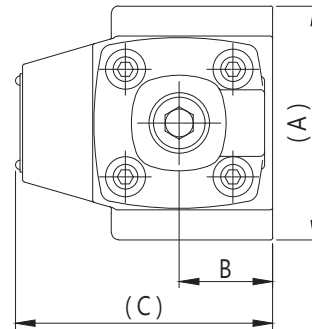

型式 MODEL	A	B	C	D	E	F
HCG-03	88	35	90.5	4	42.8	52.1
HCG-06	100	40	110	5	60.3	52.9
HCG-10	120	47.5	134	5		

型式 MODEL	G	H	I	J	K	L
HCG-03	66.7	15	17.5	11	198.5	210
HCG-06	79.4	25	17.5	11	225.5	237
HCG-10		30			274	284

單位 UNIT : mm

**安裝尺寸 INSTALLATION DIMENSIONS**

**HCT-03~10**

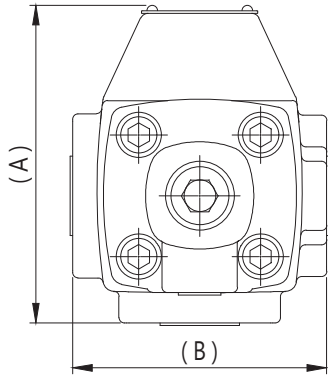

型式：外部引導外部洩油  
TYPE : EXTERNAL PILOT & DRAIN

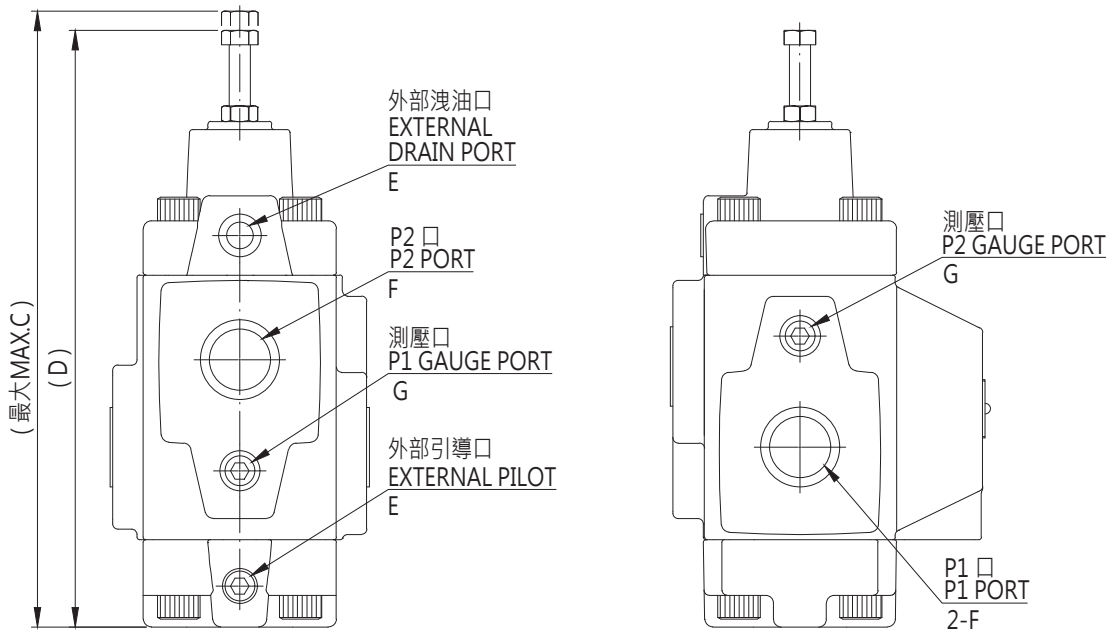

型式 MODEL	A	B	C	D	E	F	G
HCT-03	96.5	82	210	198.5	PT 1/4"	PT 3/8"	PT 1/4"
HCT-06	120	96	237	225.5	PT 1/4"	PT 3/4"	PT 1/4"
HCT-10	160	135	284	274	PT 1/4"	PT 1-1/4"	PT 1/4"