

Pressure Reducing And Check Valve

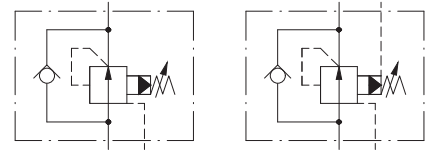

閥類型符號 SYMBOL
RC※ - ※



規格說明

SPECIFICATION

型式 MODEL		最高使用壓力 MAX. OPERATING PRESSURE kgf/cm ²	調壓範圍 PRESSURE ADJ. RANGE kgf/cm ²	最大流量 MAX. FLOW L/min	重量 WEIGHT kg	
板式安裝 SUB-PLATE MOUNTING	管式安裝 THREADED CONNECTIONS					
RCG-03	RCT-03	250	0 : 7-35	50	5.5	4.9
RCG-06	RCT-06		1 : 7-70		8.7	8.4
RCG-10	RCT-10		2 : 7-140 3 : 7-210	250	15	17

型號說明

HOW TO ORDER

RC G - 06 - 3 - 30 - TU

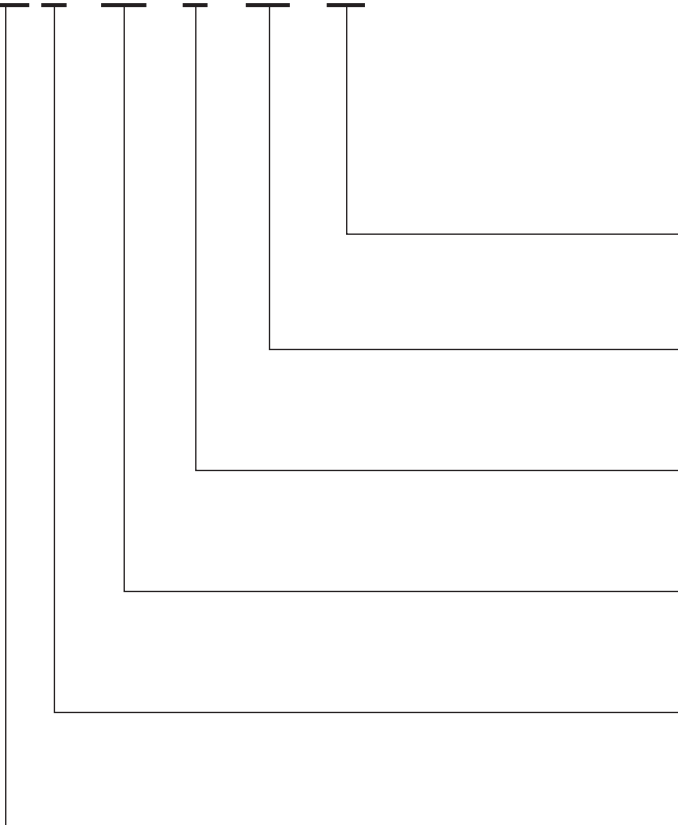

附屬品

ATTACHMENT

型式 MODEL	安裝螺絲 SOC HOL CAP SCREW	安裝扭矩 MOUNTING TORQUE N·m
RCG-03	M10 x 70L...4pcs	60~74
RCG-06	M10 x 80L...4pcs	
RCG-10	M10 x 95L...6pcs	

螺牙固定RCT-03唯一型式 ONLY FOR RCT-03 TYPE

調桿型式 ADJUSTMENT TYPE
30 : 標準型 STANDARD TYPE
32 : T型推環直結式 THRUST RING LINK TYPE

調壓範圍 PRESSURE ADJUSTING RANGE
0 : 7-35 kgf/cm² 1 : 7-70 kgf/cm²
2 : 7-140 kgf/cm² 3 : 7-210 kgf/cm²

閥規格 VALVE SIZE
03 : 3/8" 06 : 3/4" 10 : 1-1/4"

安裝型式 MOUNTING
G : 板式安裝 SUB-PLATE MOUNTING
T : 管式安裝 THREADED CONNECTIONS

系列編號 SERIES NUMBER

測試條件 PERFORMANCE CURVES

測試油黏度 TEST FLUID VISCOSITY : 35cSt

測試油溫度 TEST TEMPERATURE : 50°C

● RCG, RCT-06

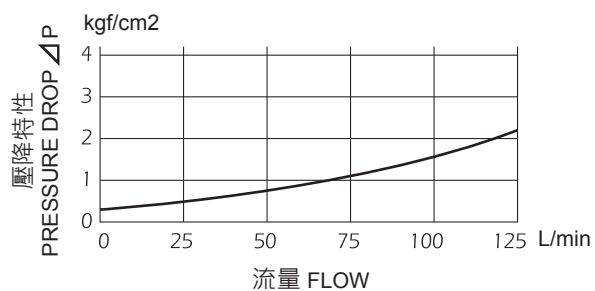

● RCG, RCT-03

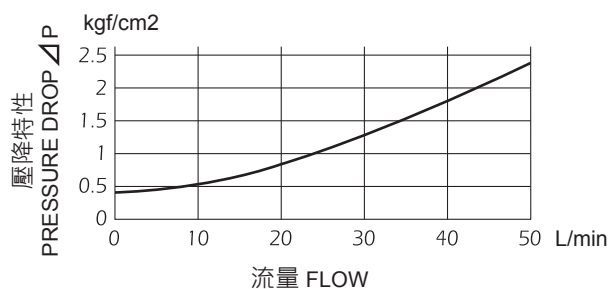

● RCG, RCT-10

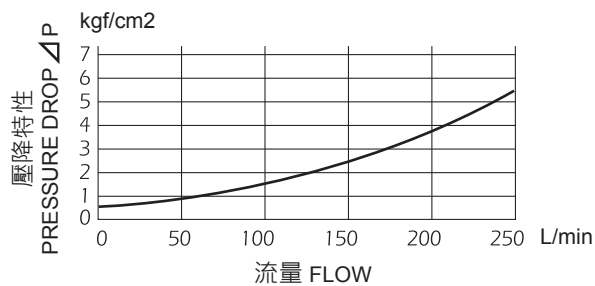

單位 UNIT : mm

安裝尺寸 INSTALLATION DIMENSIONS

RCG-03~10

通用底板尺寸
 APPLICATIVE
 SUB-PLATE DIMENSIONS
RCG-03 (MA - 06 - 1)
RCG-06 (MA - 06 - 2)
RCG-10 (MA - 06 - 3)
 (詳見 E01-05 Page E01-05)

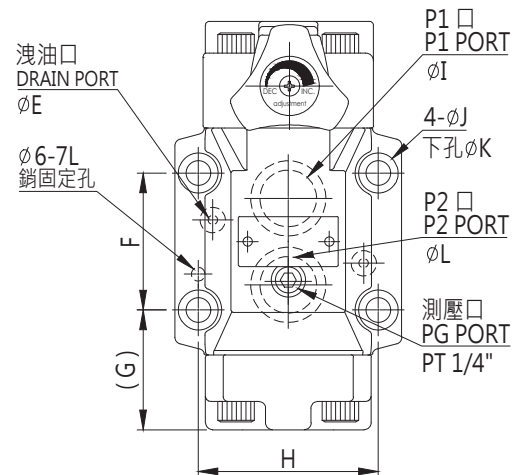
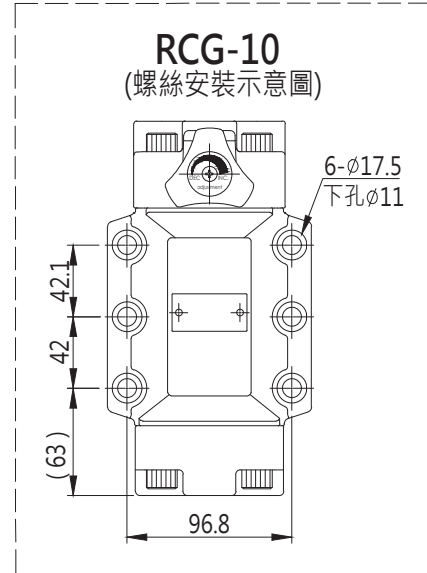
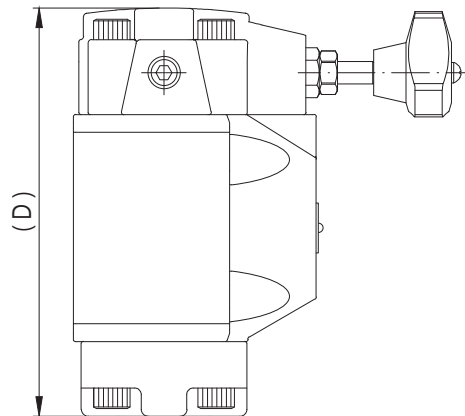
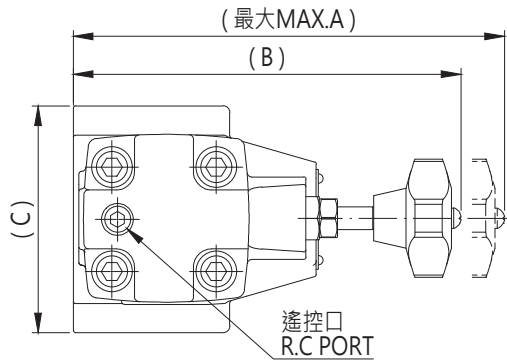

型式 MODEL	A	B	C	D	E	F
RCG-03	171.5	155.5	88	161.5	4	42.8
RCG-06	171	155	100	180	5	60.3
RCG-10	174	158	120	220	5	

型式 MODEL	G	H	I	J	K	L
RCG-03	52.1	66.7	15	17.5	11	15
RCG-06	52.9	79.4	25	17.5	11	25
RCG-10			30			30

單位 UNIT : mm

安裝尺寸 INSTALLATION DIMENSIONS

RCT-03~10

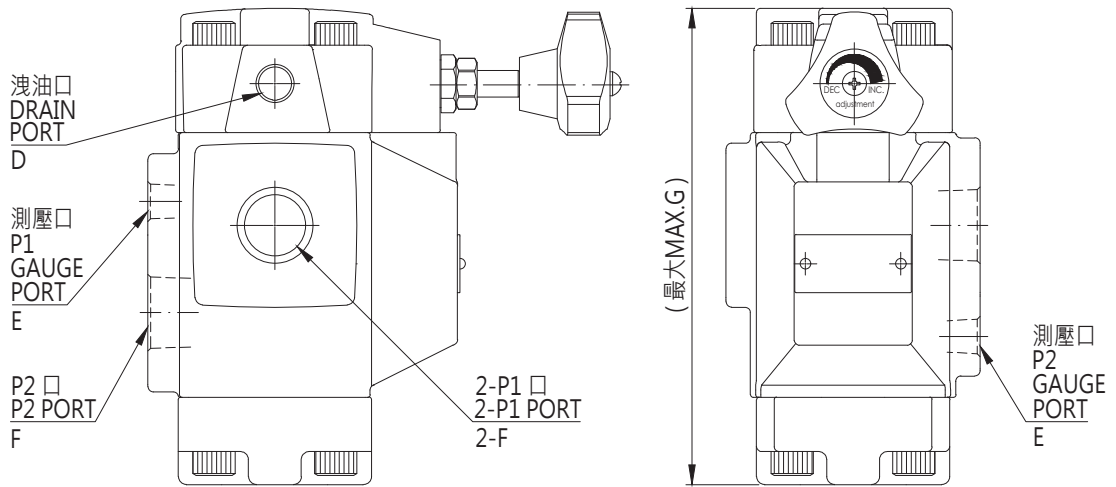
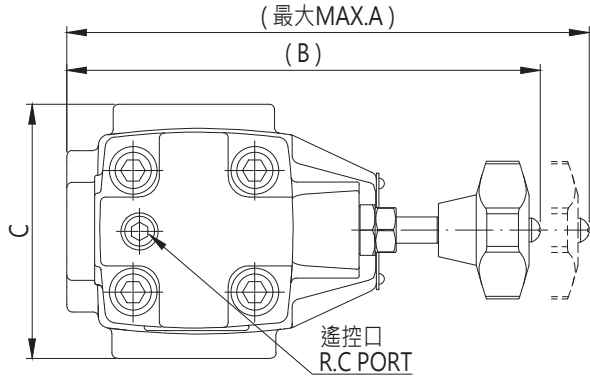

型式 MODEL	A	B	C	D	E	F	G
RCT-03	178.5	162.5	82	PT 1/4"	PT 1/4"	PT 3/8"	161.5
RCT-06	179	163	96	PT 1/4"	PT 1/4"	PT 3/4"	180
RCT-10	190.5	174.5	132	PT 1/4"	PT 1/4"	PT 1-1/4"	220