

Modular Relief Valve

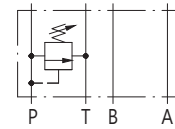

閥類型符號 SYMBOL

MRV-※



MRV-※-P

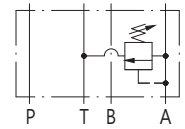

MRV-※-A

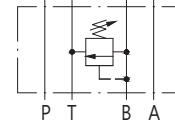

MRV-※-B

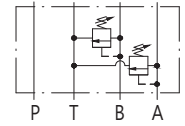

MRV-※-W

規格說明

SPECIFICATION

型式 MODEL	最高使用壓力 MAX. OPERATING PRESSURE kgf/cm ²	調壓範圍 PRESSURE ADJ. RANGE kgf/cm ²	最大流量 MAX. FLOW L/min	重量 WEIGHT kg
MRV-02	250	1 : 7-70	35	1.6
MRV-03			70	3.5
MRV-04		3 : 7-210	160	7.0
MRV-06		200	12	

型號說明

HOW TO ORDER

MRV - 02 - P - 3 - A - L

旋轉型式 KNOB TYPE

無代號為K : 把手旋鈕螺桿調整(標準型)

NO CODE FOR K : HAFT TURNING KNOB BOLT ROD ADJUST (STANDARD TYPE)

L : 內六角螺桿調整

INNER HEXANGULAR BOLT ROD ADJUST

※ L 僅供 MRV-02, MRV-03

L ONLY FOR MRV-02, MRV-03

把手方向 DIRECTION OF KNOB

A : A口側 A PORT SIDE

B : B口側(標準型) B PORT SIDE (STANDARD TYPE)

調壓範圍 PRESSURE ADJUSTING RANGE

1 : 7-70 kgf/cm² 2 : 7-140 kgf/cm²

3 : 7-210 kgf/cm²

控制油口 CONTROL OIL PORT

P : P口控制 P PORT A : A口控制 A PORT

B : B口控制 B PORT W : A,B口控制 A,B PORT

※ W 僅供 MRV-02, MRV-03

W ONLY FOR MRV-02, MRV-03

閥規格 VALVE SIZE

02 : 1/4"

03 : 3/8"

04 : 1/2"

06 : 3/4"

系列編號 SERIES NUMBER

壓降特性 PRESSURE DROP

下列壓降特性是在油液黏度 35 cSt (mm/s) 和比重 0.850 條件下測得
 Pressure drop curves based on viscosity of 35 cSt (160 SSU) and specific gravity of 0.850

● MRV-02

最低調整壓力 Min.Adj. PRESSURE

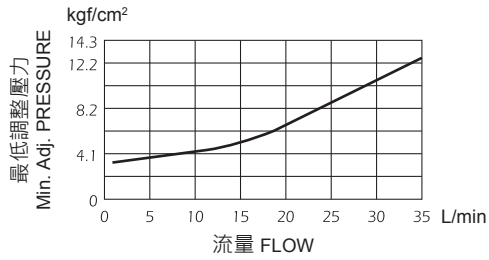

● MRV-03

最低調整壓力 Min.Adj. PRESSURE

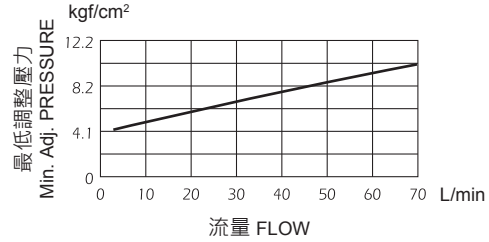

壓力降特性 PRESSURE DROP

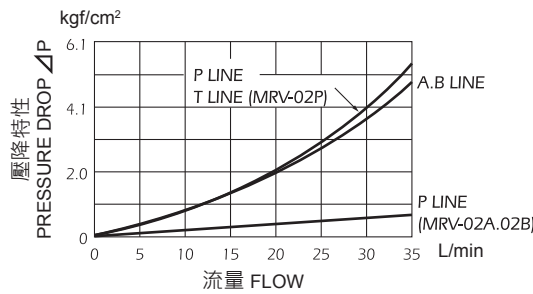

壓力降特性 PRESSURE DROP

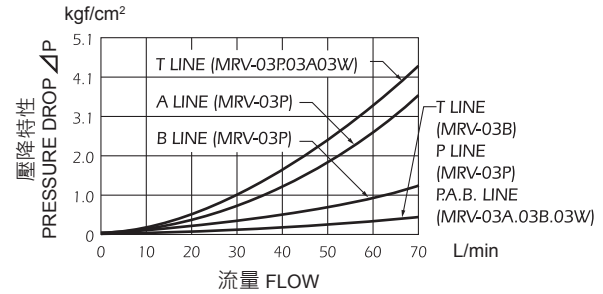

流量-壓力特性 NOMINAL OVERRIDE

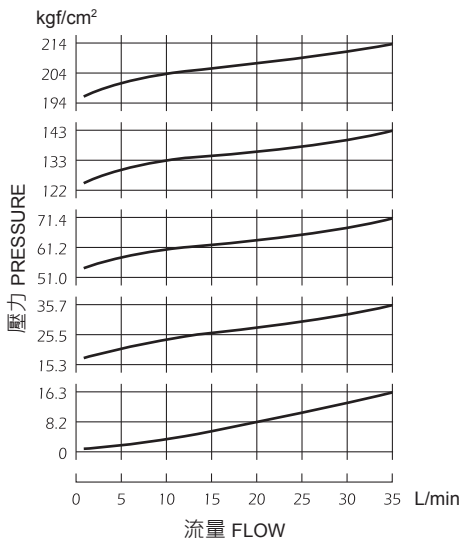

流量-壓力特性 NOMINAL OVERRIDE

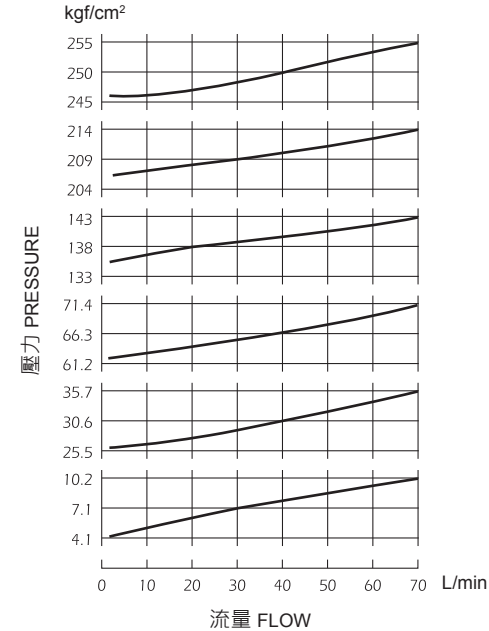

壓降特性 PRESSURE DROP

下列壓降特性是在油液黏度 35 cSt (mm/s) 和比重 0.850 條件下測得

Pressure drop curves based on viscosity of 35 cSt (160 SSU) and specific gravity of 0.850

● MRV-04

最低調整壓力 Min.Adj PRESSURE

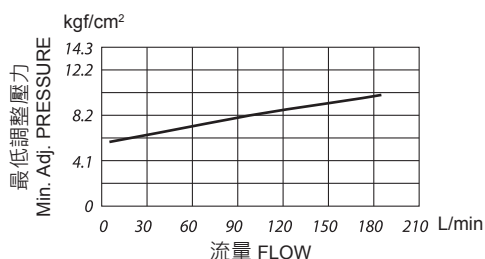

壓力降特性 PRESSURE DROP

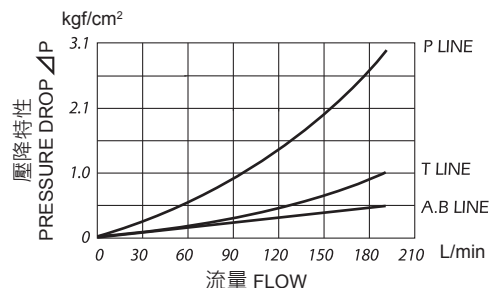

流量-壓力特性 NOMINAL OVERRIDE

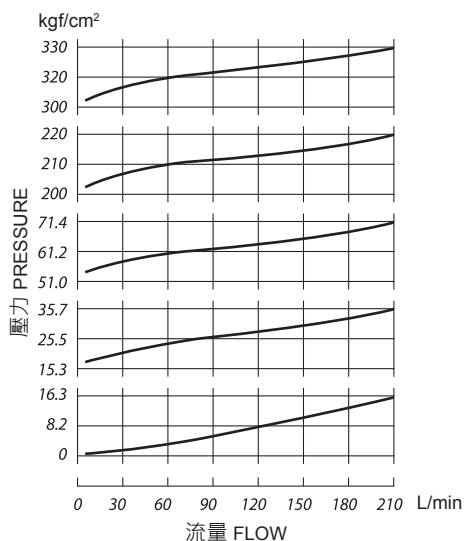

測試條件 PERFORMANCE CURVES

測試油黏度 TEST FLUID VISCOSITY : 35cSt

測試油溫度 TEST TEMPERATURE : 50°C

● MRV-02

最小流量 Min.FLOW :

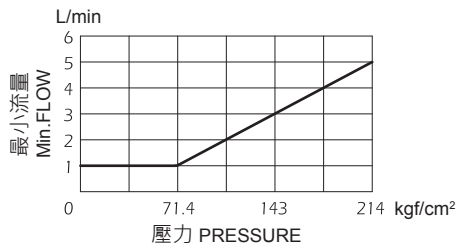

● MRV-03

最小流量 Min.FLOW :

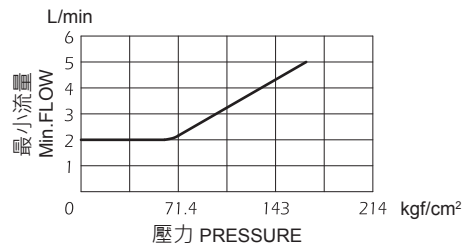

● MRV-04

最小流量 Min.FLOW :

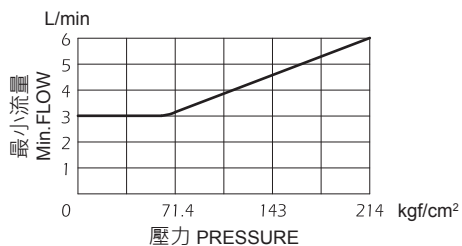

安裝尺寸 INSTALLATION DIMENSIONS

MRV-02

MRV-02-L

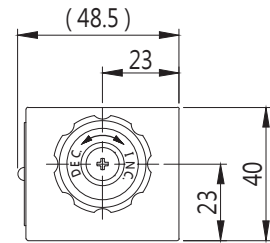
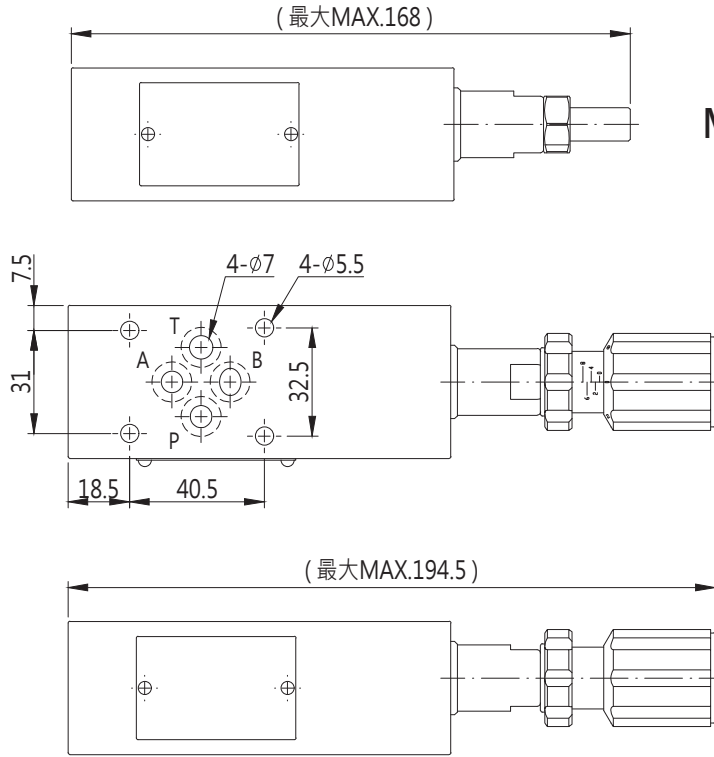

MRV-02-W

MRV-02-W-L

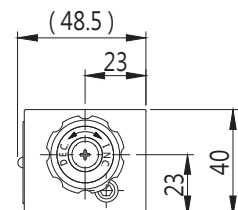
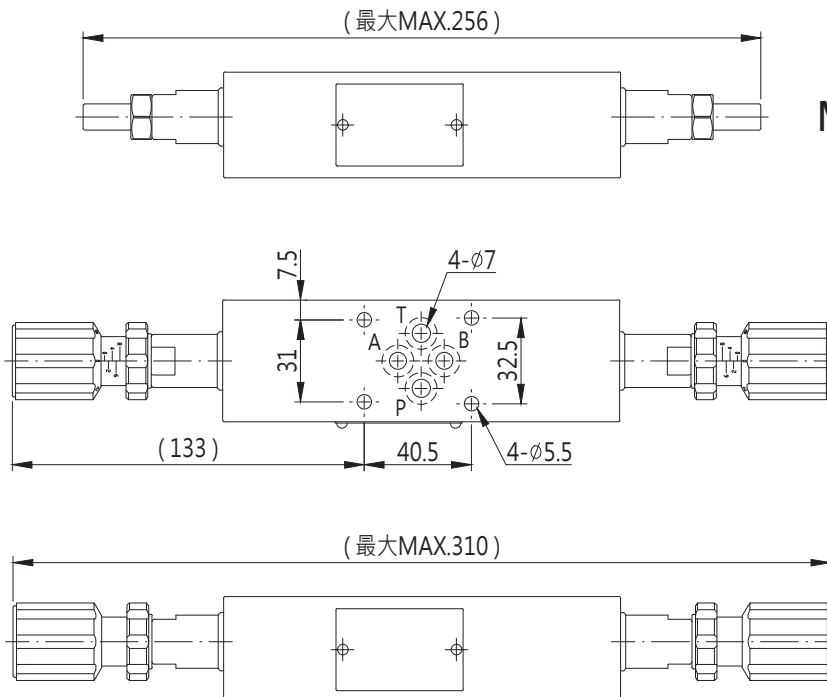

單位 UNIT : mm

安裝尺寸 INSTALLATION DIMENSIONS

MRV-03

MRV-03-L

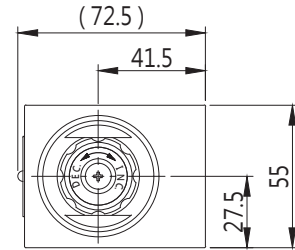
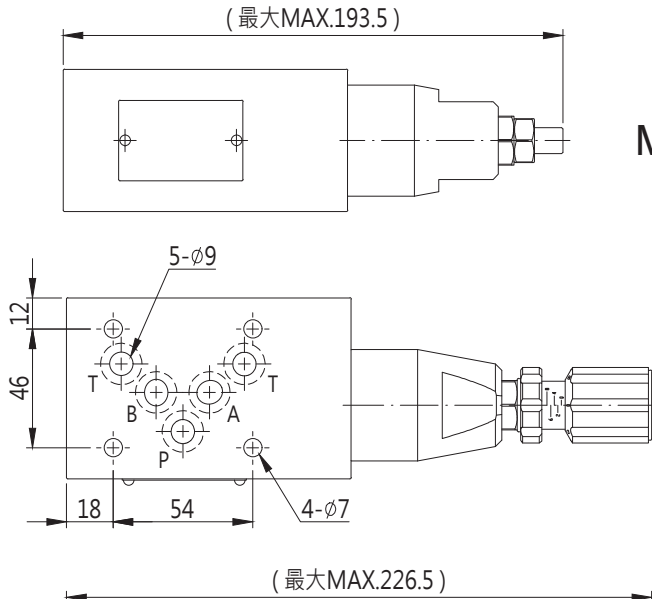

MRV-03-W

MRV-03-W-L

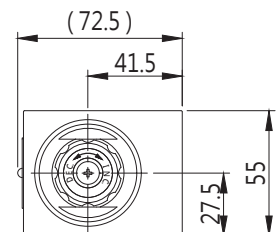
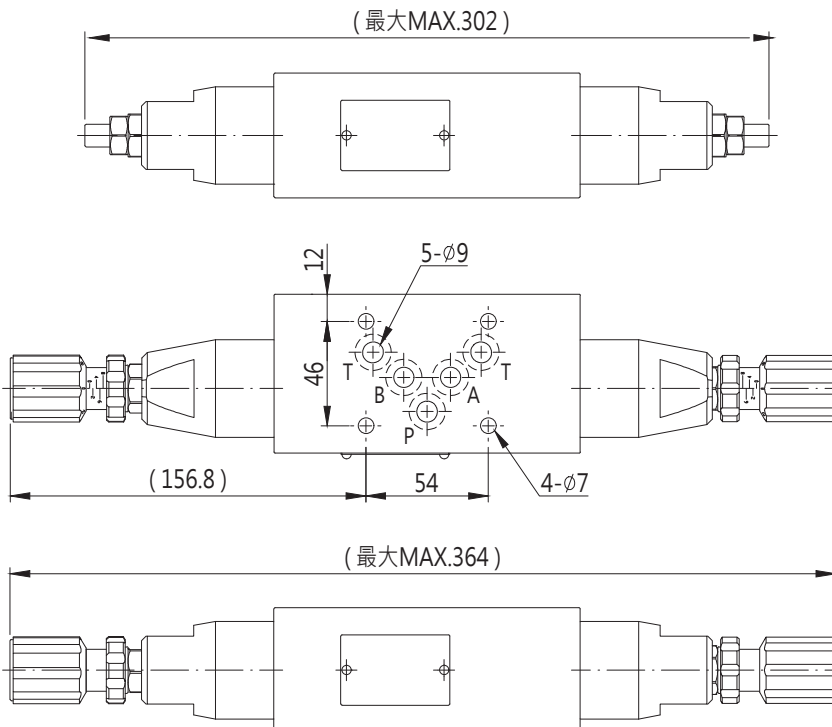

安裝尺寸 INSTALLATION DIMENSIONS

MRV-04-A

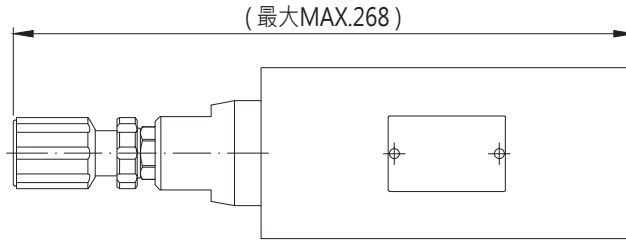
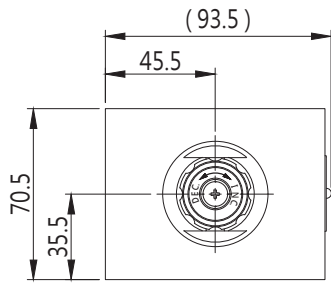
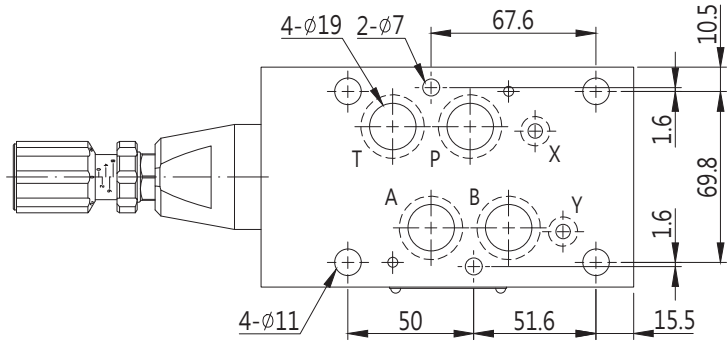

MRV-06-A

