

Modular Throttle And Check Valve

閥類型符號 SYMBOL
MTCV - ※

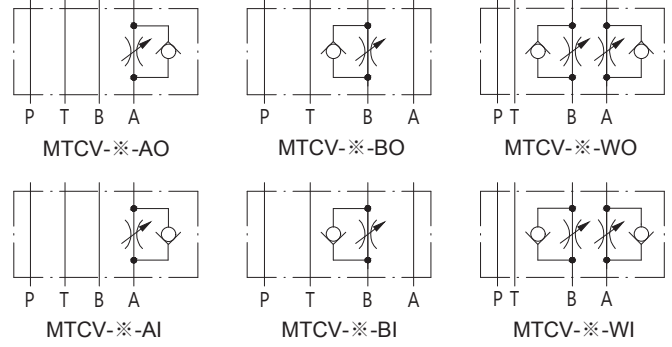

規格說明 SPECIFICATION

型式 MODEL	最高使用壓力 MAX. OPERATING PRESSURE kgf/cm ²	最大流量 MAX. FLOW L/min	重量 WEIGHT kg
MTCV-02-AO/BO/AI/BI	標準型 STD. : 250 H : 350	35	1.3
MTCV-02-WO/WI			1.4
MTCV-03-AO/BO/AI/BI		70	2.7
MTCV-03-WO/WI			2.8
MTCV-04-AO/BO/AI/BI		190	7.5
MTCV-04-WO/WI			
MTCV-06-AO/BO/AI/BI		300	13
MTCV-06-WO/WI			

型號說明 HOW TO ORDER

H - MTCV - 02 - WO - L

旋轉型式 KNOB TYPE
無代號為K : 把手旋鈕螺桿調整(標準型)
NO CODE FOR K : HAFT TURNING KNOB BOLT ROD ADJUST (STANDARD TYPE)

L : 內六角螺桿調整
INNER HEXANGULAR BOLT ROD ADJUST
※ L僅供MTCV-06
L ONLY FOR MTCV-06

控制油口 CONTROL OIL PORT
AO : A口回油控制 A PORT METER OUT
BO : B口回油控制 B PORT METER OUT
WO : A,B口回油控制 A,B PORT METER OUT
AI : A口入油控制 A PORT METER IN
BI : B口入油控制 B PORT METER IN
WI : A,B口入油控制 A,B PORT METER IN

閥規格 VALVE SIZE
02 : 1/4" 03 : 3/8" 04 : 1/2" 06 : 3/4"

系列編號 SERIES NUMBER

最高使用壓力 MAX. OPERATING PRESSURE
無代號 : 標準型 250 kgf/cm²
NO CODE : STANDARD TYPE 250 kgf/cm²
H : 350 kgf/cm²

測試條件 PERFORMANCE CURVES

測試油黏度 TEST FLUID VISCOSITY : 35cSt

測試油溫度 TEST TEMPERATURE : 50°C

● MTCV-02

● MTCV-03

壓力降特性 PRESSURE DROP

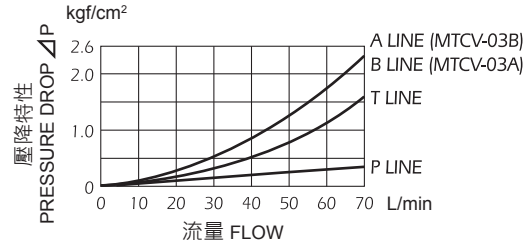
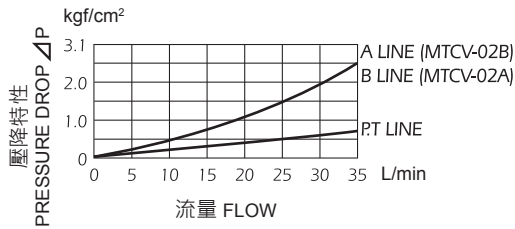

自由流時壓力降特性 PRESSURE DROP FOR FREE FLOW

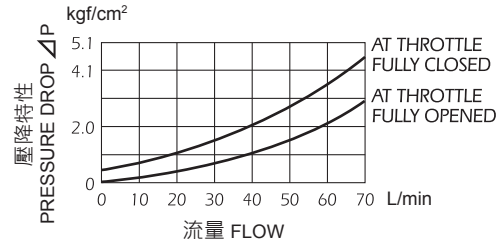
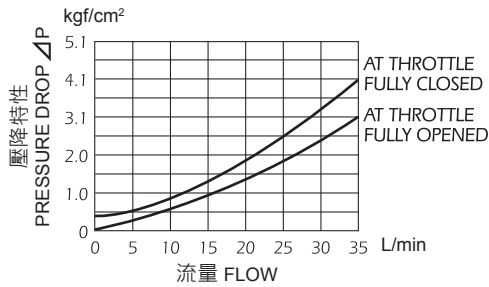

節流旋鈕開度—流量特性 METERED FLOW v.s. DIAL POSITION

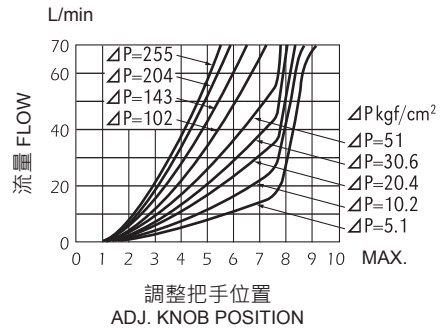
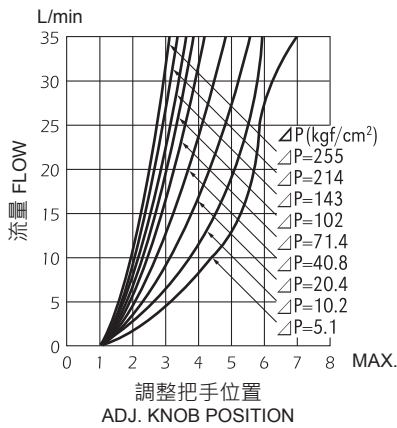

調整螺桿全開時壓力降特性 PRESSURE DROP AT THROTTLE FULLY OPENED

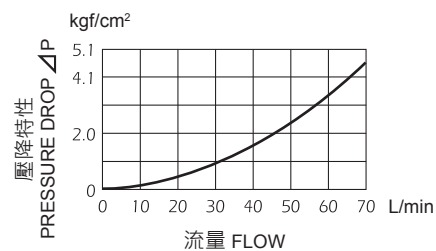
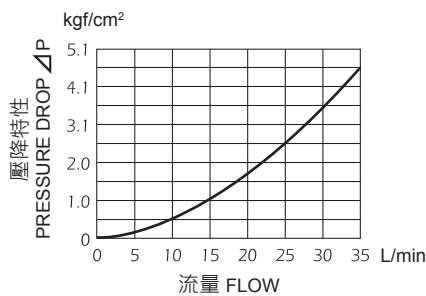

測試條件 PERFORMANCE CURVES

測試油黏度 TEST FLUID VISCOSITY : 35cSt

測試油溫度 TEST TEMPERATURE : 50°C

● MTCV-04

● MTCV-06

壓力降特性 PRESSURE DROP

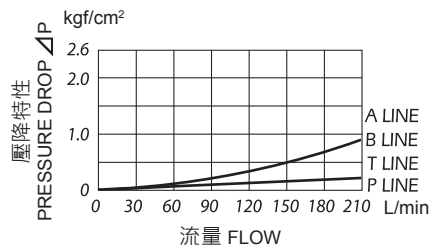
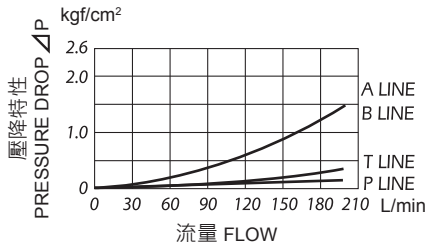

自由流時壓力降特性 PRESSURE DROP FOR FREE FLOW

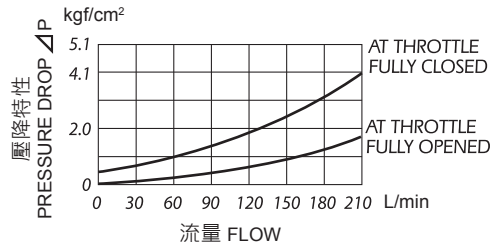
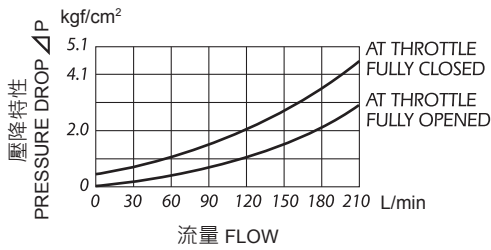

節流旋鈕開度-流量特性 METERED FLOW v.s. DIAL POSITION

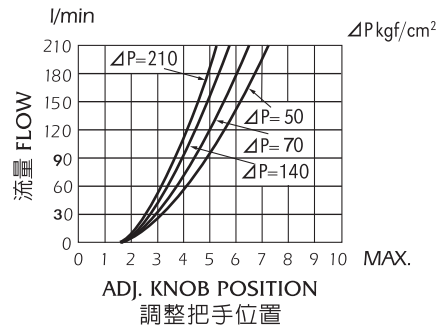
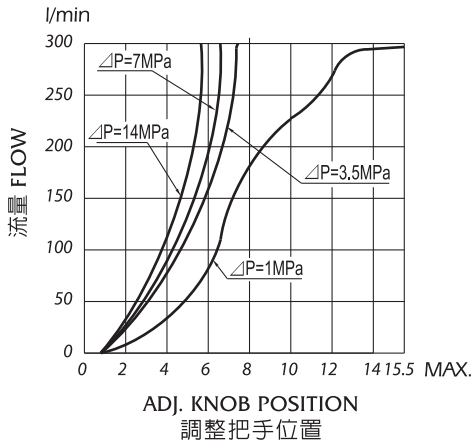

調整螺桿全開時壓力降特性 PRESSURE DROP AT THROTTLE FULLY OPENED

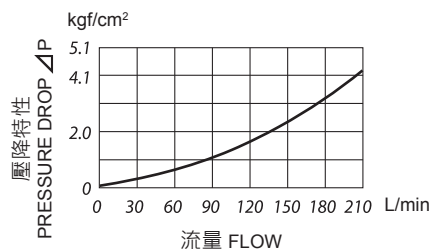
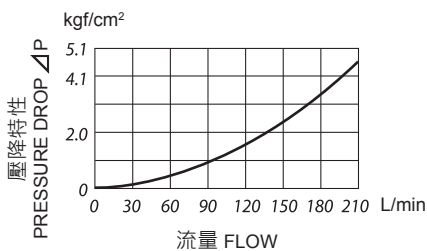

單位 UNIT : mm

安裝尺寸 INSTALLATION DIMENSIONS

MTCV-02

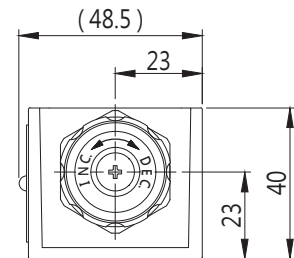
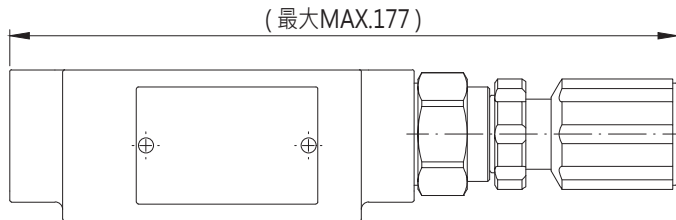
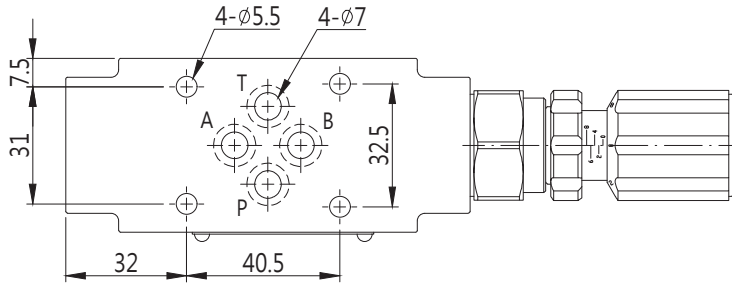

MTCV-02-W0/WI

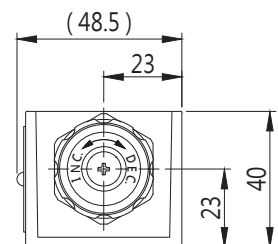
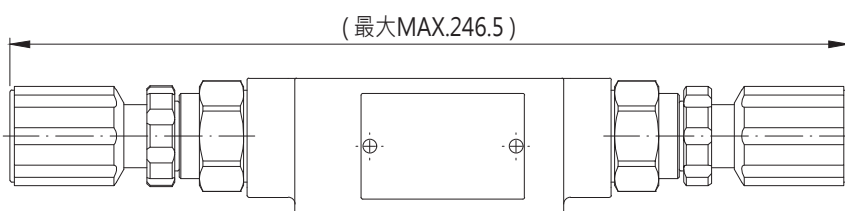
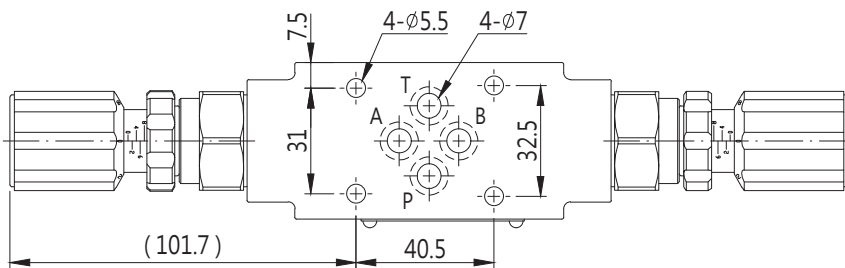

安裝尺寸 INSTALLATION DIMENSIONS

MTCV-03

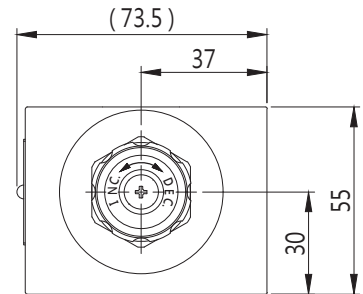
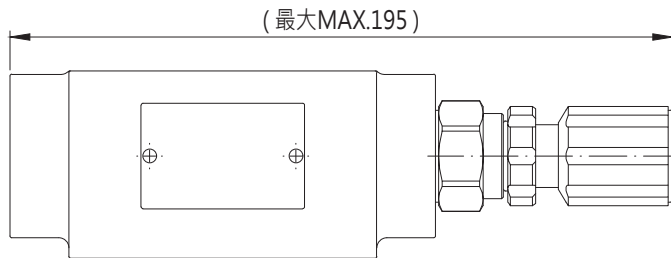
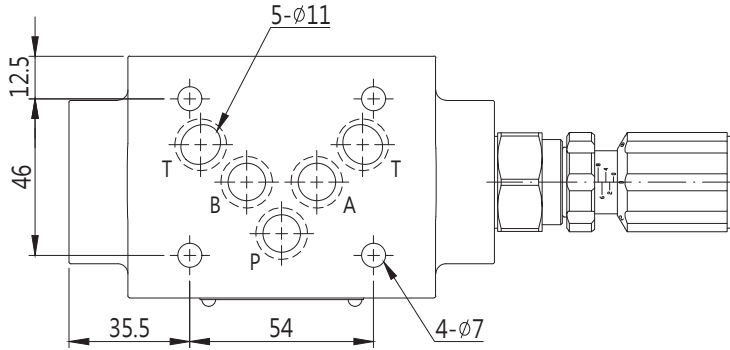

MTCV-03-W0/WI

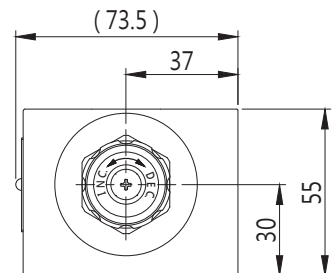
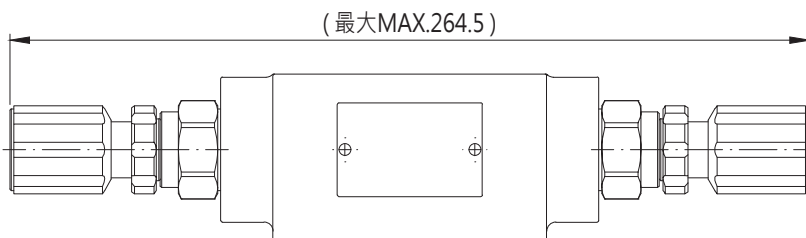
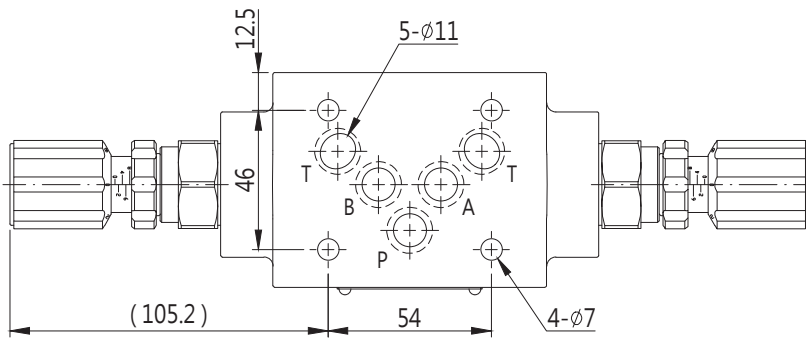

單位 UNIT : mm

安裝尺寸 INSTALLATION DIMENSIONS

MTCV-04

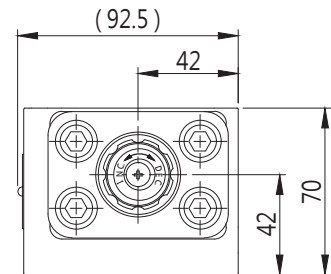
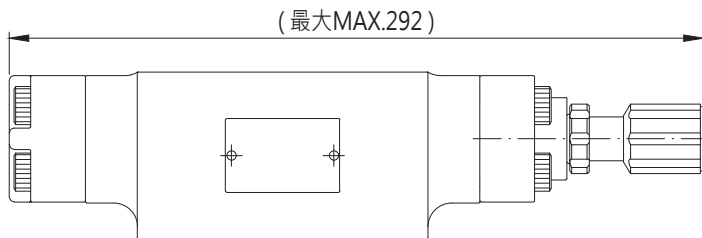
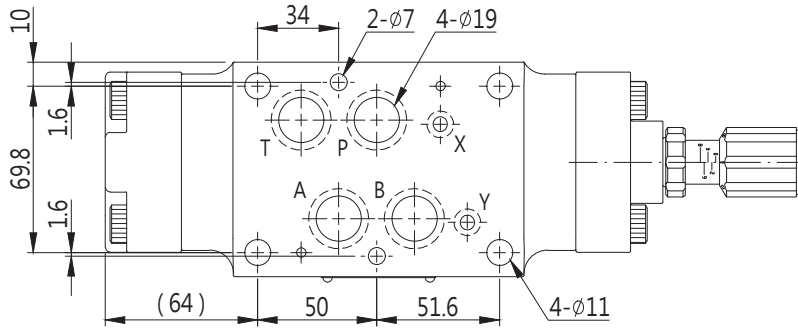

MTCV-04-WO/WI

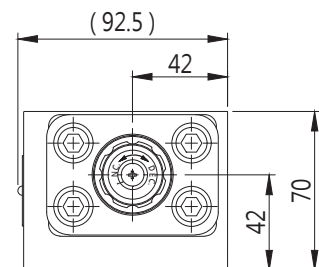
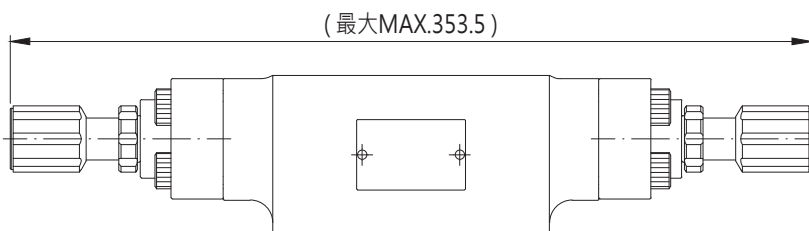
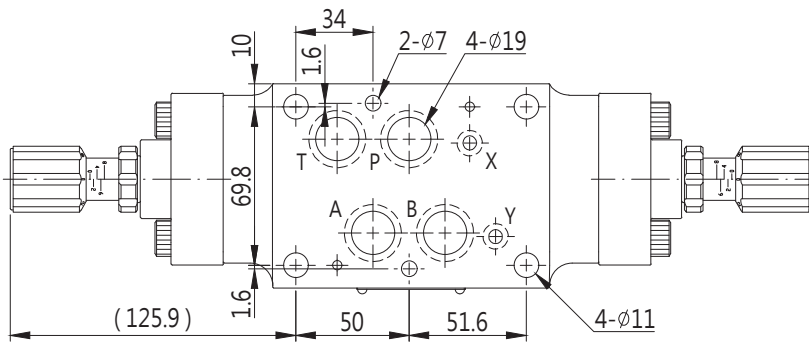

安裝尺寸 INSTALLATION DIMENSIONS

MTCV-06-L

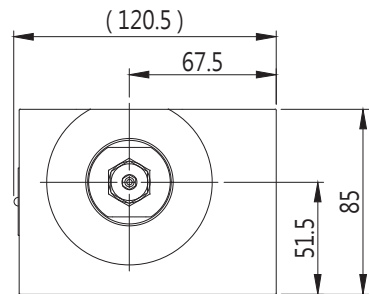
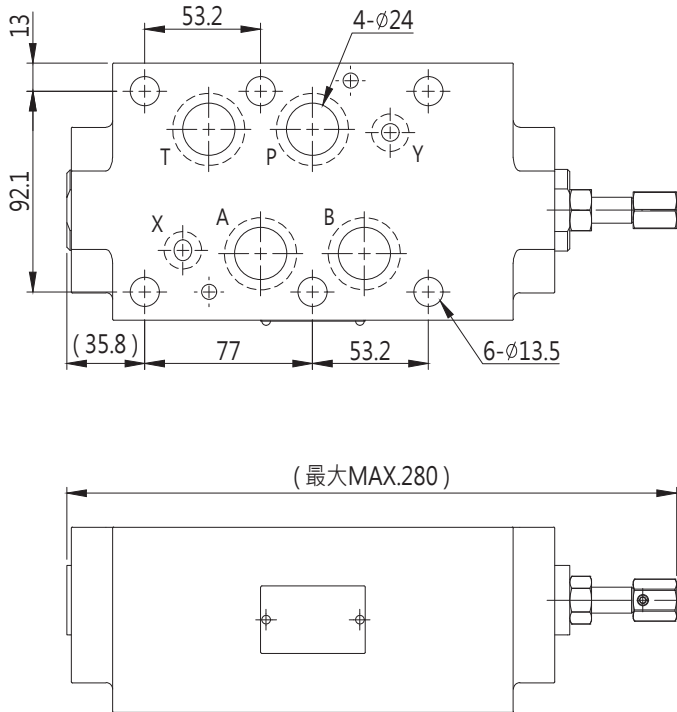

MTCV-06-WO/WI-L

