

Pilot-to-open check valve with standard pilot

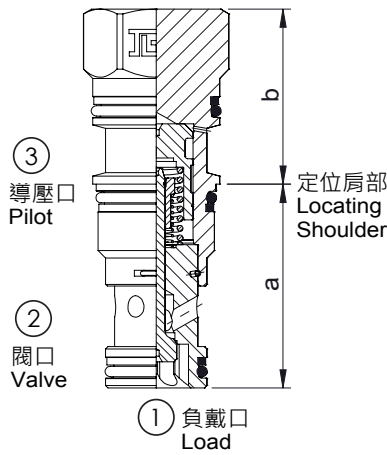

閥類型符號 SYMBOL
J-CK※B

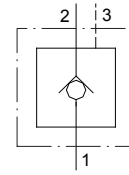

插裝閥尺寸

	a	b
		X
J-CKBB	31	31.8
J-CKCB	35.1	30.2
J-CKEB	35.1	35.1
J-CKGB	46	46
J-CKIB	63.5	58.7

性能曲線

PERFORMANCE CURVES

壓損曲線

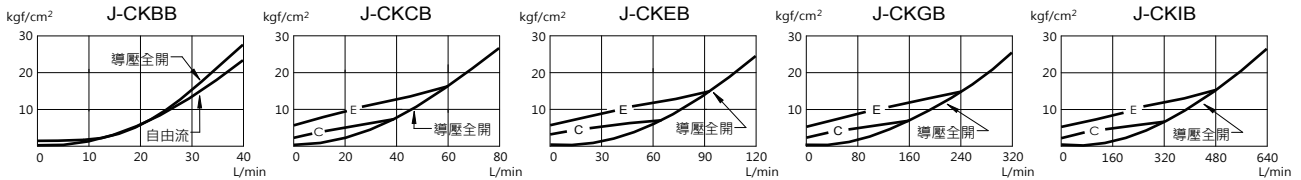

規格說明

SPECIFICATION

型式 MODEL	最高使用壓力 MAX. OPERATING PRESSURE (kgf/cm ²)	最大流量 MAX. FLOW L/min	安裝扭矩 MOUNTING TORQUE N·m	成型孔 CAVITY	重量 WEIGHT kg
J-CKBB	350	30	27-33	T-163A	0.09
J-CKCB		60	41-47	T-11A	0.13
J-CKEB		120	61-68	T-2A	0.24
J-CKGB		240	203-217	T-17A	0.53
J-CKIB		480	474-508	T-19A	1.21

型號說明

HOW TO ORDER

J - CKEB - C - X

控制方式 CONTROL
X: 不可調 NOT ADJUSTABLE

開啟壓力 CRACKING PRESSURE
A: 0.3 kgf/cm² B: 1.0 kgf/cm² C: 2.0 kgf/cm²
D: 3.5 kgf/cm² E: 5.0 kgf/cm² F: 7.0 kgf/cm²
※ J-CKBB 僅供 C, E J-CKBB ONLY SELECT C, E

閥規格 VALVE SIZE
CKBB: 30 L/min CKCB: 60 L/min
CKEB: 120 L/min CKGB: 240 L/min
CKIB: 480 L/min

系列編號 SERIES NUMBER