

Pilot-to-close check valve

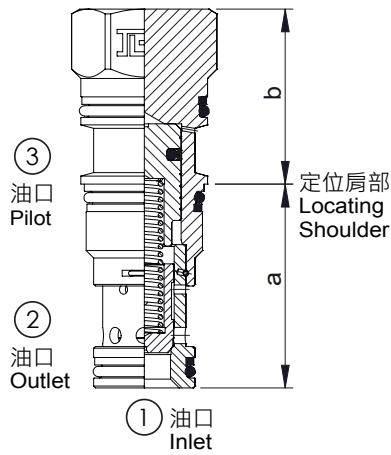

閥類型符號 SYMBOL
J-CO※A

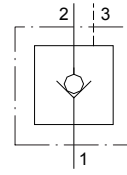

插裝閥尺寸

	a	b
		X
J-CODA	35	30.2
J-COFA	35	35.1
J-COHA	46	46

性能曲線

PERFORMANCE CURVES

壓損曲線

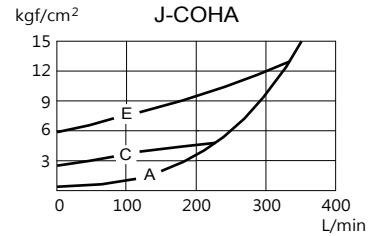
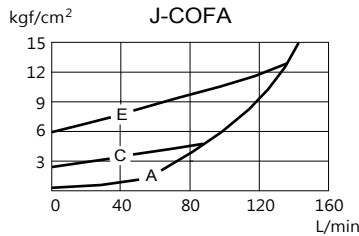
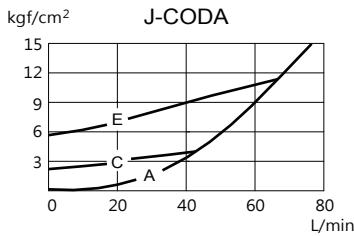

規格說明

SPECIFICATION

型式 MODEL	最高使用壓力 MAX. OPERATING PRESSURE (kgf/cm ²)	最大流量 MAX. FLOW L/min	安裝扭矩 MOUNTING TORQUE N·m	成型孔 CAVITY	重量 WEIGHT kg
J-CODA	350	80	41-47	T-11A	0.13
J-COFA		160	61-68	T-2A	0.23
J-COHA		320	203-217	T-17A	0.51

型號說明

HOW TO ORDER

J - COFA - C - X

控制方式 CONTROL
X: 不可調 NOT ADJUSTABLE

開啟壓力 CRACKING PRESSURE
A : 0.3 kgf/cm² B : 1.0 kgf/cm² C : 2.0 kgf/cm²
D : 3.5 kgf/cm² E : 5.0 kgf/cm² F : 7.0 kgf/cm²
G : 10.5 kgf/cm² J : 9.5 kgf/cm²
※ G為J-CODA & J-COHA唯一型式
SPRING G ONLY FOR J-CODA & J-COHA
※ J為J-COFA唯一型式
SPRING J ONLY FOR J-COFA

閥規格 VALVE SIZE
CODA : 80 L/min COFA : 160 L/min
COHA : 320 L/min

系列編號 SERIES NUMBER