

Check Valve

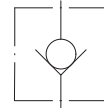

閥類型符號 SYMBOL
CRG - ※



規格說明 SPECIFICATION

型式 MODEL		最高使用壓力 MAX. OPERATING PRESSURE (kgf/cm ²)	開啟壓力 CRACKING PRESSURE kgf/cm ²	流量 RATED FLOW L/min	重量 WEIGHT kg	
CRG-03-10	CRG-03-20	標準型 STD. : 250 H : 350	05 : 0.35	40	1.7	1.9
CRG-06-10	CRG-06-20		50 : 3.5	125	4.2	3.2
CRG-10-10	CRG-10-20		75 : 5.0	250	7.7	6.0

型號說明 HOW TO ORDER

H - CR G - 06 - 05 - 10

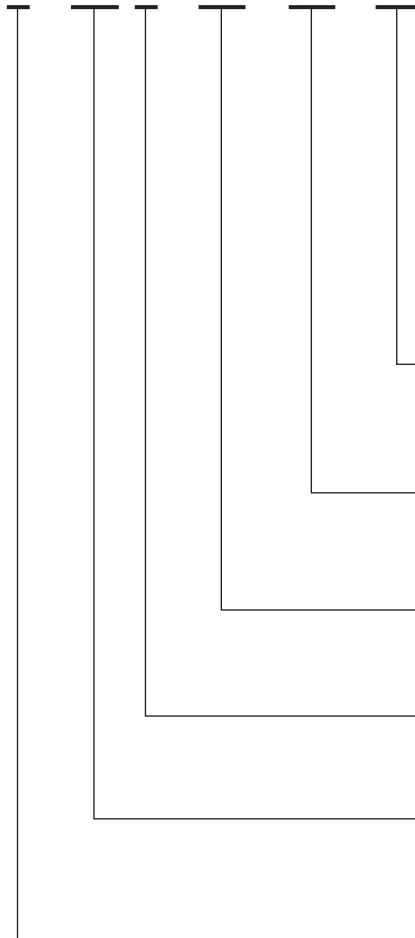

附屬品 ATTACHMENT

型式 MODEL	安裝螺絲 SOC HOL CAP SCREW	安裝扭矩 MOUNTING TORQUE N.m
CRG-03-10	M10 x 50L...4pcs	60~74
CRG-06-10	M16 x 60L...4pcs	253~310
CRG-10-10	M20 x 75L...4pcs	493~603
CRG-03-20	M10 x 45L...4pcs	60~74
CRG-06-20	M10 x 50L...4pcs	
CRG-10-20	M10 x 55L...6pcs	

設計編號 DESIGN NUMBER
10 : 非ISO規格 NO-ISO STANDARD
20 : 標準ISO規格 ISO STANDARD

開啟壓力 CRACKING PRESSURE
05 : 0.35 kgf/cm² 50 : 3.5 kgf/cm²
75 : 5.0 kgf/cm²

閥規格 VALVE SIZE
03 : 3/8" 06 : 3/4" 10 : 1-1/4"

安裝型式 MOUNTING
G : 板式安裝 SUB-PLATE MOUNTING

系列編號 SERIES NUMBER

最大使用壓力 MAX. OPERATING PRESSURE
無代號 : 標準型 250 kgf/cm²
NO CODE : STANDARD TYPE 250 kgf/cm²
H : 350 kgf/cm²

測試條件

PERFORMANCE CURVES

測試油黏度 TEST FLUID VISCOSITY : 35cSt

測試油溫度 TEST TEMPERATURE : 50°C

● CRG-03

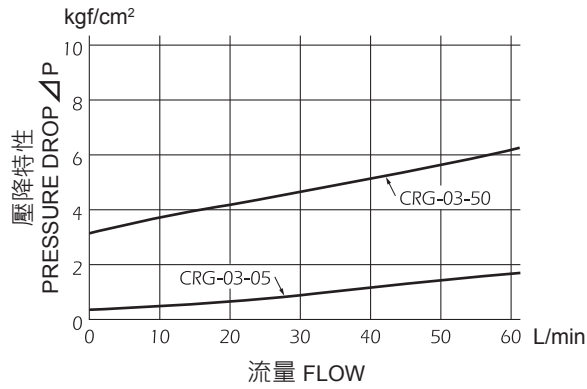

● CRG-06

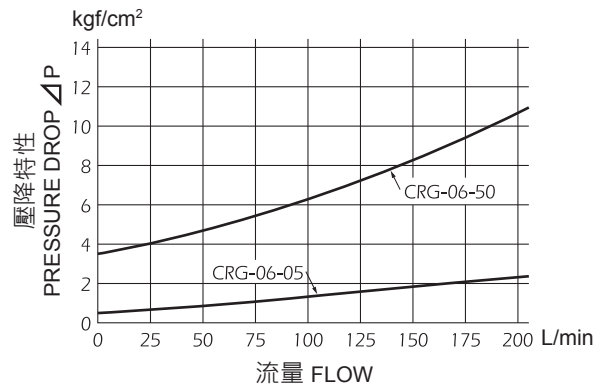

● CRG-10

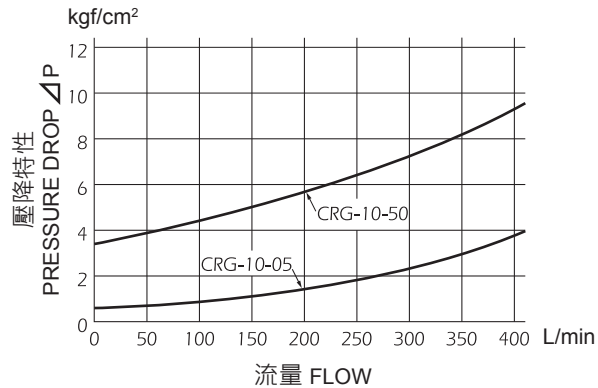

單位 UNIT : mm

安裝尺寸 INSTALLATION DIMENSIONS

CRG-03~10-10

通用底板尺寸

APPLICATIVE
SUB-PLATE DIMENSIONS

CRG-03-10 (MC - 01 - 1)

CRG-06-10 (MC - 01 - 2)

CRG-10-10 (MC - 01 - 3)

(詳見 E01-08 Page E01-08)

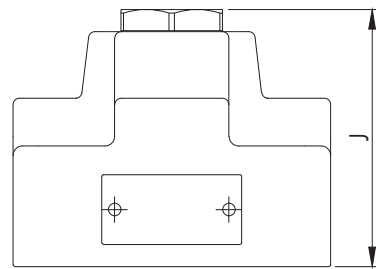
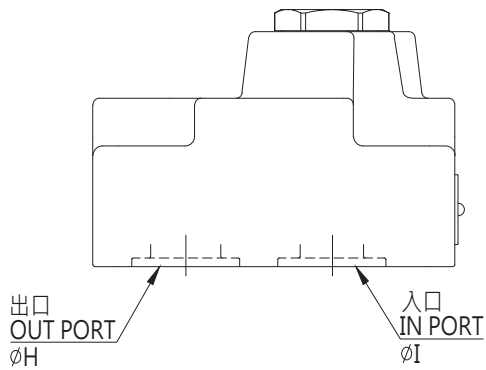
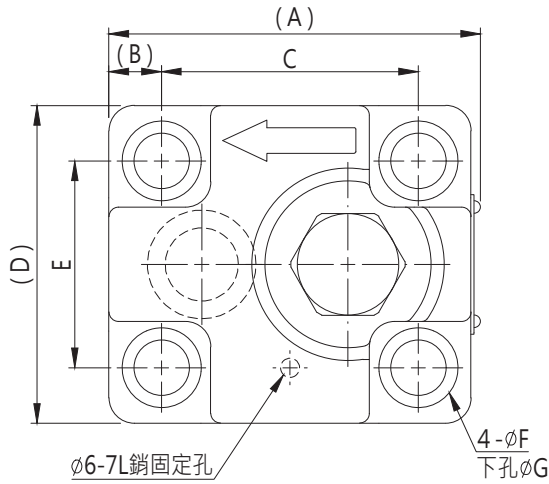

型式 MODEL	A	B	C	D	E
CRG-03-10	84	10.4	60.3	70	47.6
CRG-06-10	117	16.6	80.9	100	65.1
CRG-10-10	136	20.5	92.1	130	92.1

型式 MODEL	F	G	H	I	J
CRG-03-10	17.5	11	15	15	69
CRG-06-10	25	17.5	22	20	81
CRG-10-10	31.5	21.5	30	30	98

單位 UNIT : mm

安裝尺寸 INSTALLATION DIMENSIONS

CRG-03~10-20

通用底板尺寸
 APPLICATIVE SUB-PLATE DIMENSIONS

CRG-03-20 (MC - 01 - 4)

CRG-06-20 (MC - 01 - 5)

CRG-10-20 (MC - 01 - 6)

(詳見 E01-08 Page E01-08)

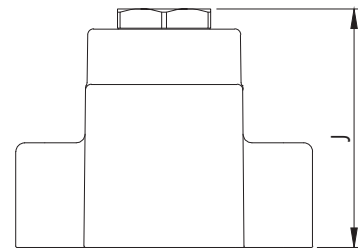
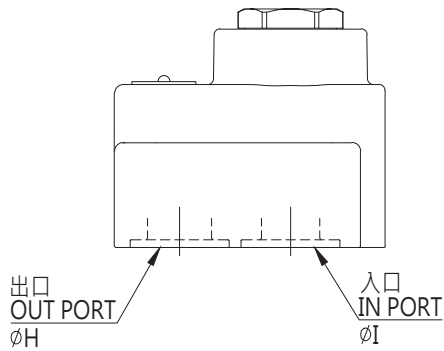
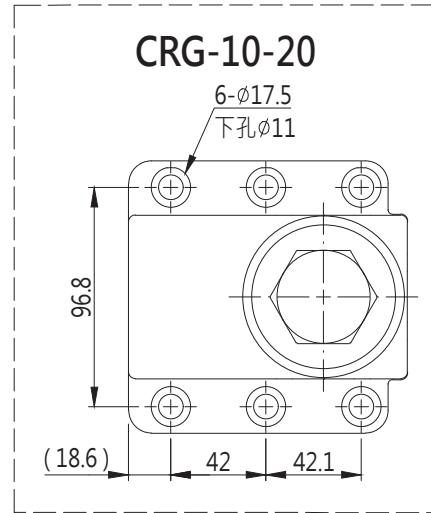
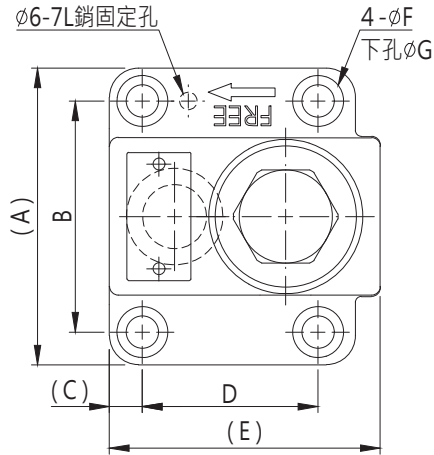

型式 MODEL	A	B	C	D	E
CRG-03-20	90	66.7	17.5	42.9	75
CRG-06-20	102	79.4	11.3	60.3	93
CRG-10-20	120				126

型式 MODEL	F	G	H	I	J
CRG-03-20	17.5	11	15	15	71
CRG-06-20	17.5	11	22	20	82
CRG-10-20			28	26	96