

Pilot Operated Check Valve

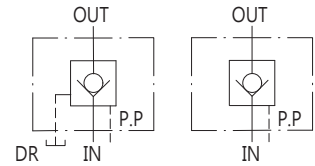

閥類型符號 SYMBOL

CPD※ - ※



規格說明

SPECIFICATION

型式 MODEL		最高使用壓力 MAX. OPERATING PRESSURE kgf/cm ²	開啟壓力 CRACKING PRESSURE kgf/cm ²	流量 RATED FLOW L/min	重量 WEIGHT kg	
板式安裝 SUB-PLATE MOUNTING	管式安裝 THREADED CONNECTIONS					
CPDG-03	CPDT-03	250	05 : 0.35 50 : 3.5 75 : 5.0	40	4.6	3.8
CPDG-06	CPDT-06			125	7.5	6.4
CPDG-10	CPDT-10			250	12.8	12.8
CPDF-10				250	15.4	

型號說明

HOW TO ORDER

CPD G - 06 - 05 - E - 10 - FPT

附屬品

ATTACHMENT

型式 MODEL	安裝螺絲 SOC HOL CAP SCREW	安裝扭矩 MOUNTING TORQUE N·m
CPDG-03	M10 x 70L...4pcs	60~74
CPDG-06	M10 x 80L...4pcs	
CPDG-10	M10 x 90L...6pcs	

法蘭型式 TYPE OF PIPE FLANG

FPT : PT口法蘭 (附高低壓法蘭) PT PORT FLANG
(ADD ACCIDENT PRESSURE PIPE FLANG)

FT : T口法蘭 (附低壓法蘭) T PORT FLANG
(ADD LOW PRESSURE PIPE FLANG)

FP : P口法蘭 (附高壓法蘭) P PORT FLANG
(ADD HIGH PRESSURE PIPE FLANG)

無代號 **NO CODE** : 不附法蘭 NOT ADD PIPE FLANG

設計編號 DESIGN NUMBER

10 : 標準型 STANDARD TYPE

20 : 閥規格10唯一型式 ONLY FOR TYPE 10

控油方式 PILOT AND DRAIN TYPE

E : 外部引導內部洩油 EXTERNAL PILOT INTERNAL DRAIN

ET : 外部引導外部洩油 EXTERNAL PILOT & DRAIN

開啟壓力 CRACKING PRESSURE

05 : 0.35 kgf/cm² **50** : 3.5 kgf/cm² **75** : 5.0 kgf/cm²

閥規格 VALVE SIZE

03 : 3/8" **06** : 3/4" **10** : 1-1/4"

安裝型式 MOUNTING

G : 板式安裝 SUB-PLATE MOUNTING

T : 管式安裝 THREADED CONNECTIONS

F : 法蘭安裝 FLANGED CONNECTIONS

系列編號 SERIES NUMBER

測試條件 PERFORMANCE CURVES

測試油黏度 TEST FLUID VISCOSITY : 35cSt

測試油溫度 TEST TEMPERATURE : 50°C

壓降特性 PRESSURE DROP

● CPDG, CPDT-03

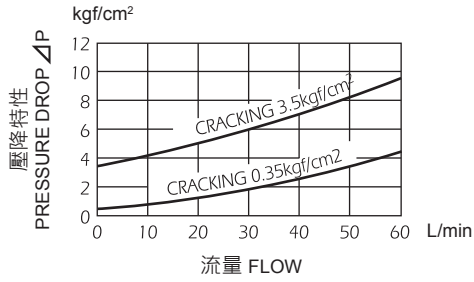

● CPDG, CPDT-06

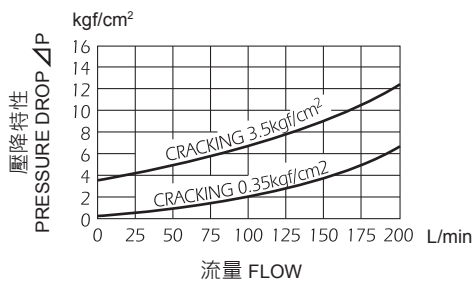

● CPDG, CPDT-10

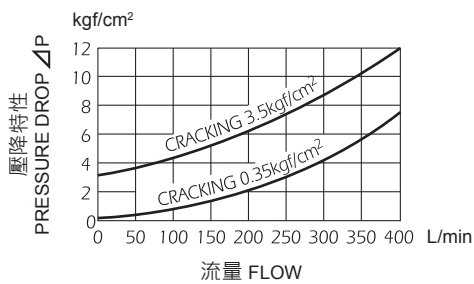

最小引導壓力特性 Min. PILOT PRESSURE

● CPDG, CPDT-03

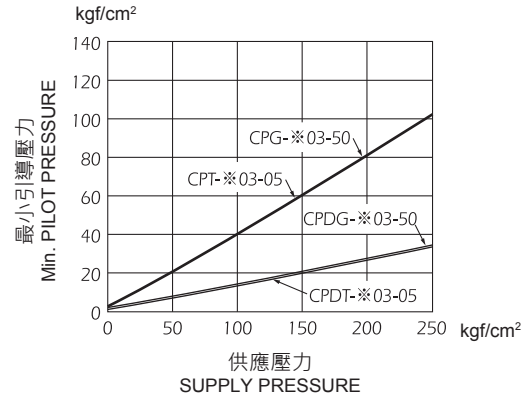

● CPDG, CPDT-06

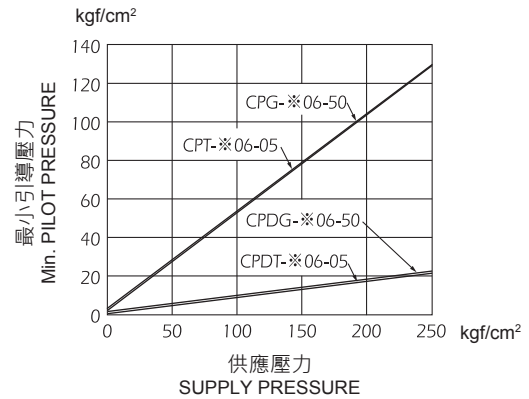

● CPDG, CPDT-10

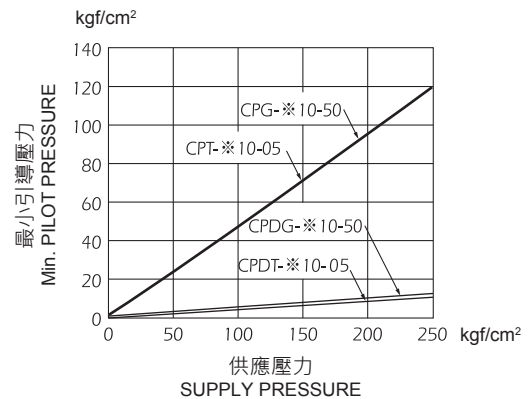

單位 UNIT : mm

安裝尺寸 INSTALLATION DIMENSIONS

CPDG-03~10

通用底板尺寸
 APPLICATIVE
 SUB-PLATE DIMENSIONS
CPDG-03 (MA - 05 - 1)
CPDG-06 (MA - 05 - 2)
CPDG-10 (MA - 05 - 3)
 (詳見 E01-04 Page E01-04)

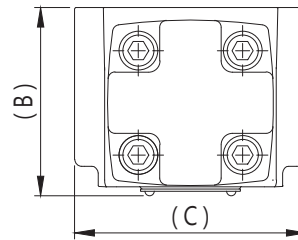
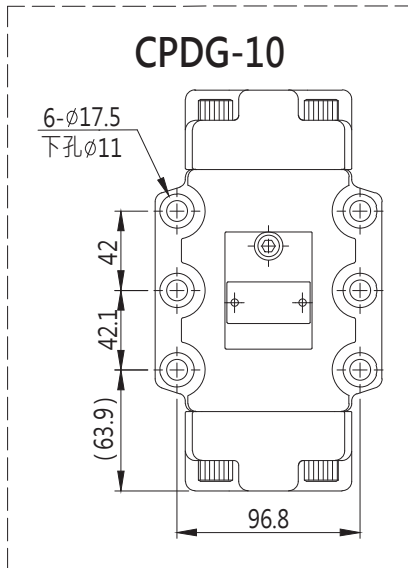

自由流量出口
 FREE FLOW
 OUT PORT
 控制流量入口
 CONTROL FLOW
 IN PORT
 φA

自由流量出口
 FREE FLOW
 OUT PORT
 控制流量入口
 CONTROL FLOW
 IN PORT
 φA

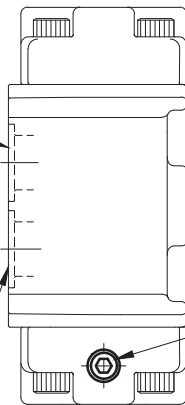

外部洩油口(DR)

測壓口
 GAUGE PORT
 H

φ6-7L
 鎖固定孔

外部引導口
 EXTERNAL PILOT

4-φI
 下孔φJ

引導口(P.P)
 PT 1/4"

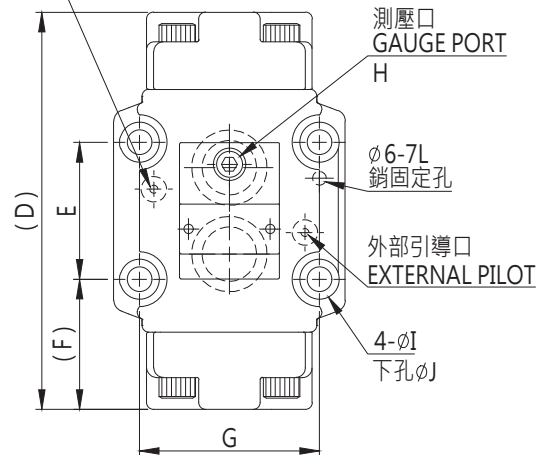

型式 MODEL	A	B	C	D	E
CPDG-03	15	71	88	149	42.8
CPDG-06	25	83	102	175	60.3
CPDG-10	30	94	120	212	

型式 MODEL	F	G	H	I	J
CPDG-03	53.1	66.7	PT 1/4"	17.5	11
CPDG-06	57.4	79.4	PT 1/4"	17.5	11
CPDG-10			PT 1/4"		

安裝尺寸 INSTALLATION DIMENSIONS

CPDT-03~10

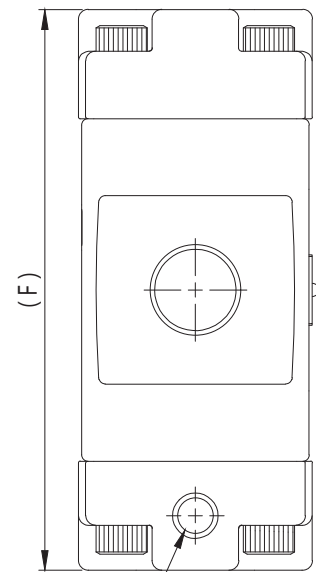
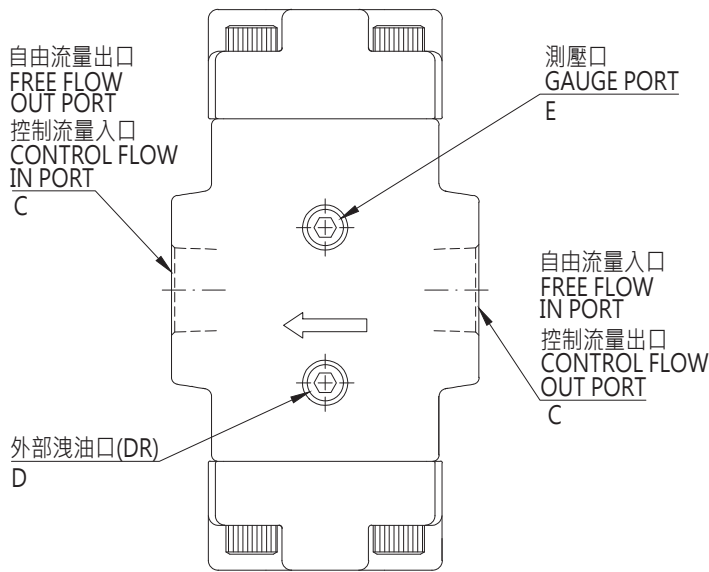
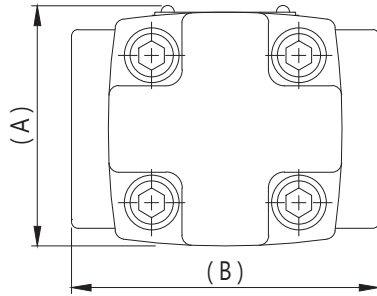

外部引導口 (P.P) (EXTERNAL GUIDANCE PORT) D

型式 MODEL	A	B	C	D	E	F
CPDT-03	65	80	PT 3/8"	PT 1/4"	PT 1/4"	149
CPDT-06	75	96	PT 3/4"	PT 1/4"	PT 1/4"	175
CPDT-10	98	142	PT 1-1/4"	PT 1/4"	PT 1/4"	212



單位 UNIT : mm

安裝尺寸 INSTALLATION DIMENSIONS

CPDF-06,10

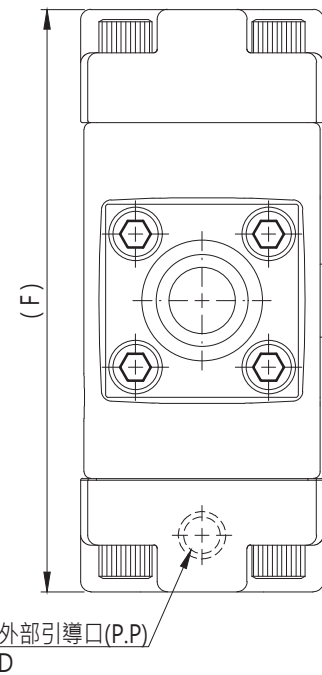
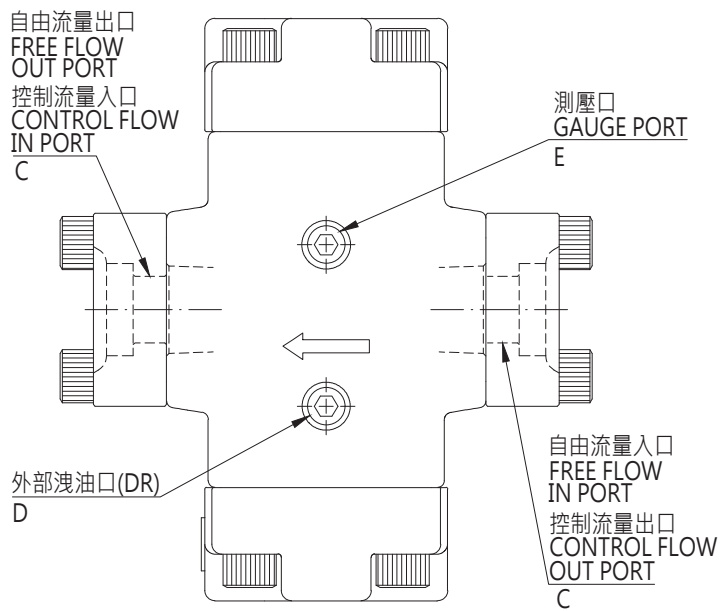
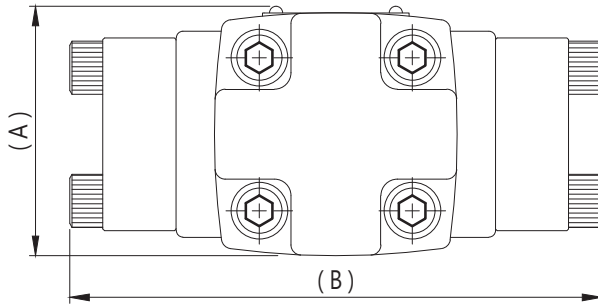

型式 MODEL	A	B	C	D	E	F
CPDF-06	75	160	20	PT 1/4"	PT 1/4"	175
CPDF-10	97	222	31.5	PT 1/4"	PT 1/4"	212