

## Manually Operated Directional Valve



### 規格說明

### SPECIFICATION

型式 MODEL		最高使用壓力 MAX. OPERATING PRESSURE kgf/cm <sup>2</sup>	容許背壓 BACK PRESSURE kgf/cm <sup>2</sup>		最大流量 MAX. FLOW L/min		重量 WEIGHT kg	
板式安裝 SUB-PLATE MOUNTING	管式安裝 THREADED CONNECTIONS		20	100	30	50	1.5	4.5
DMG-02	DMT-03	250						
	DMT-04		100	140	50	180	3.6	11.5
DMG-03	DMT-06							
	DMT-10							

### 型號說明

### HOW TO ORDER

**DM T - 03 - 3 G6**

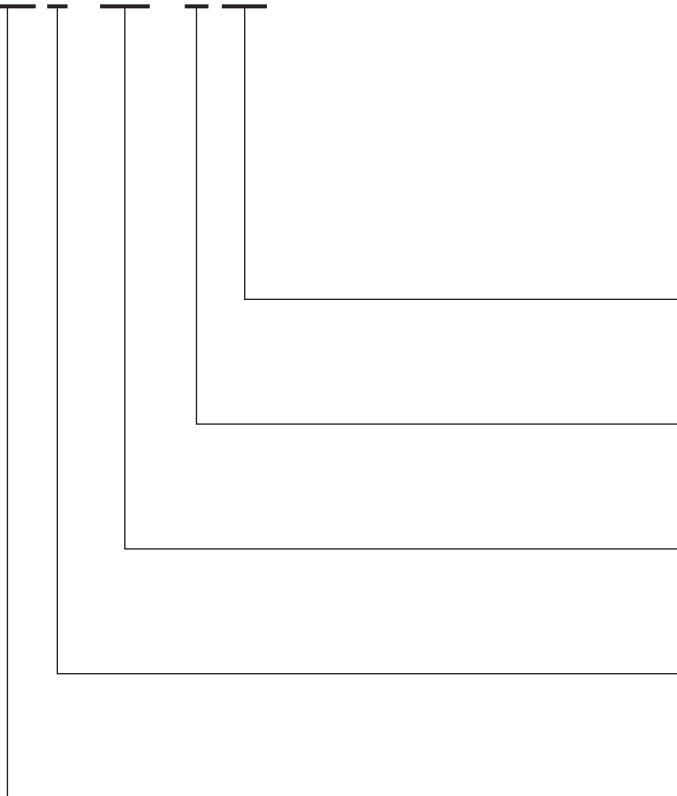

### 附屬品

### ATTACHMENT

型式 MODEL	安裝螺絲 SOC HOL CAP SCREW	安裝扭矩 MOUNTING TORQUE N·m
<b>DMG-02</b>	M5 x 45L...4pcs	8~9
<b>DMG-03</b>	M6 x 40L...4pcs	12~15

主軸型式 · 見C12-03頁  
SPOOL TYPE (AS C12-03)

閥位數 NUMBER OF VALVE POSITION  
2 : 2 POSITION  
3 : 3 POSITION

閥規格 VALVE SIZE  
02 : 1/4"    03 : 3/8"    04 : 1/2"  
06 : 3/4"    10 : 1-1/4"

安裝型式 MOUNTING  
G : 板式安裝 SUB-PLATE MOUNTING  
T : 管式安裝 THREADED CONNECTIONS

系列編號 SERIES NUMBER

### 測試條件 PERFORMANCE CURVES

測試油黏度 TEST FLUID VISCOSITY : 35cSt

測試油溫度 TEST TEMPERATURE : 50°C

壓力降特性 PRESSURE DROP

特性圖 PERFORMANCE CHART

#### DMG, DMT-03

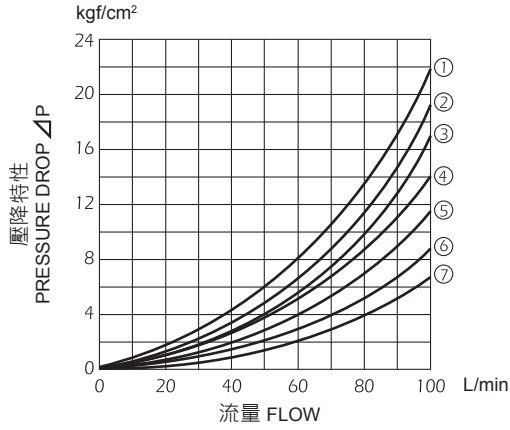

#### DMG, DMT-03

滑軸型式 SPOOL TYPE	壓力降曲線代碼 PRESSURE DROP LINE NUMBER				
	P→A	B→T	P→B	A→T	P→T
C2	④	⑤	④	⑤	-
C3	⑥	⑥	⑥	⑥	⑥
C4	④	⑦	④	⑦	-
C5	⑥	⑤	④	⑥	②
C6	⑤	⑤	⑤	⑤	①
C60	⑤	⑤	⑤	⑤	①

#### DMT-04

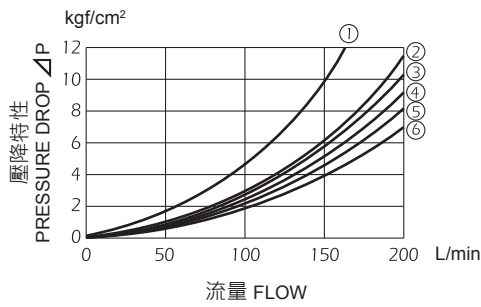

#### DMT-04

滑軸型式 SPOOL TYPE	壓力降曲線代碼 PRESSURE DROP LINE NUMBER				
	P→A	B→T	P→B	A→T	P→T
C2	⑤	②	⑤	④	-
C3	⑥	③	⑥	⑤	③
C4	⑤	④	⑤	⑤	-
C40	⑤	④	⑤	⑤	-
C5	⑤	②	④	⑤	①
C6	②	③	④	②	①
C60	②	③	④	②	①

#### DMT-06

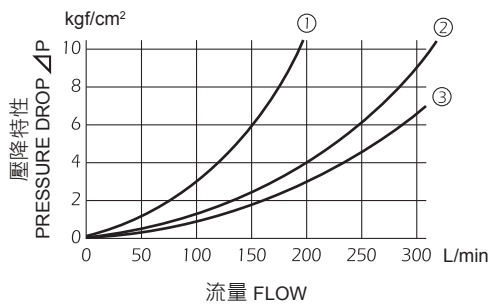

#### DMT-06

滑軸型式 SPOOL TYPE	壓力降曲線代碼 PRESSURE DROP LINE NUMBER				
	P→A	B→T	P→B	A→T	P→T
C2	②	②	②	②	-
C3	③	②	③	②	②
C4	②	③	②	②	-
C5	③	②	②	②	-
C6	③	②	③	②	①
C60	③	②	③	②	①

#### DMT-10

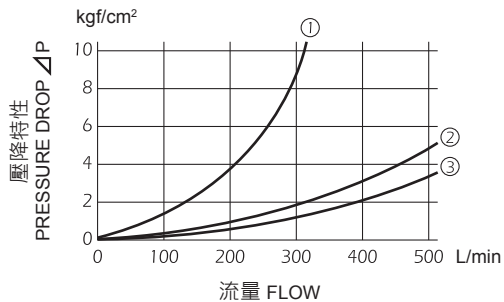

#### DMT-10

滑軸型式 SPOOL TYPE	壓力降曲線代碼 PRESSURE DROP LINE NUMBER				
	P→A	B→T	P→B	A→T	P→T
C2	③	②	③	②	-
C3	③	②	③	②	②
C4	③	③	③	②	-
C5	③	②	③	②	-
C6	③	③	③	③	①
C60	③	③	③	③	①

單位 UNIT : mm

## 安裝尺寸 INSTALLATION DIMENSIONS

### DMG-02,03

通用底板尺寸

APPLICATIVE

SUB-PLATE DIMENSIONS

**DMG-02 ( MC - 02 - 1 )**

**DMG-03 ( MC - 03 - 1 )**

(詳見 E01-09 Page E01-09)

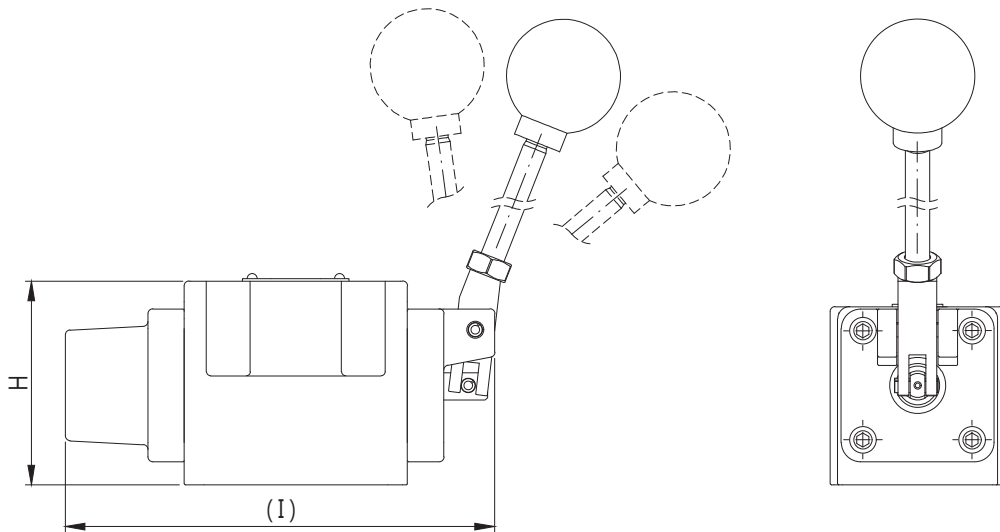
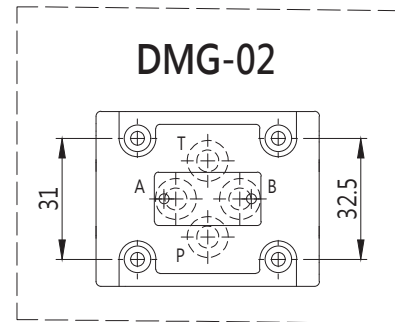
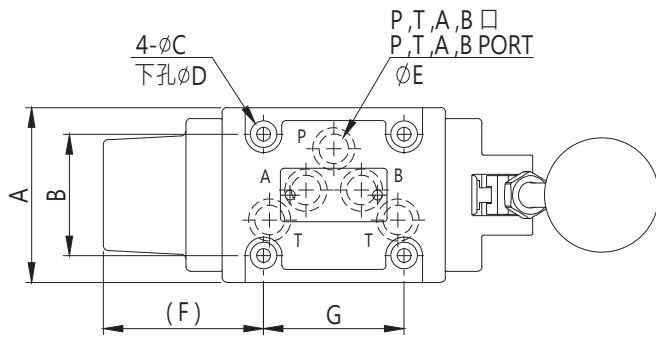

型式 MODEL	A	B	C	D	E	F	G	H	I
DMG-02	48		9.5	5.5	7	46.5	40.5	49	125
DMG-03	70	46	11	7	11	66	54	67	177

## 安裝尺寸

## INSTALLATION DIMENSIONS

單位 UNIT : mm

### DMT-03~10

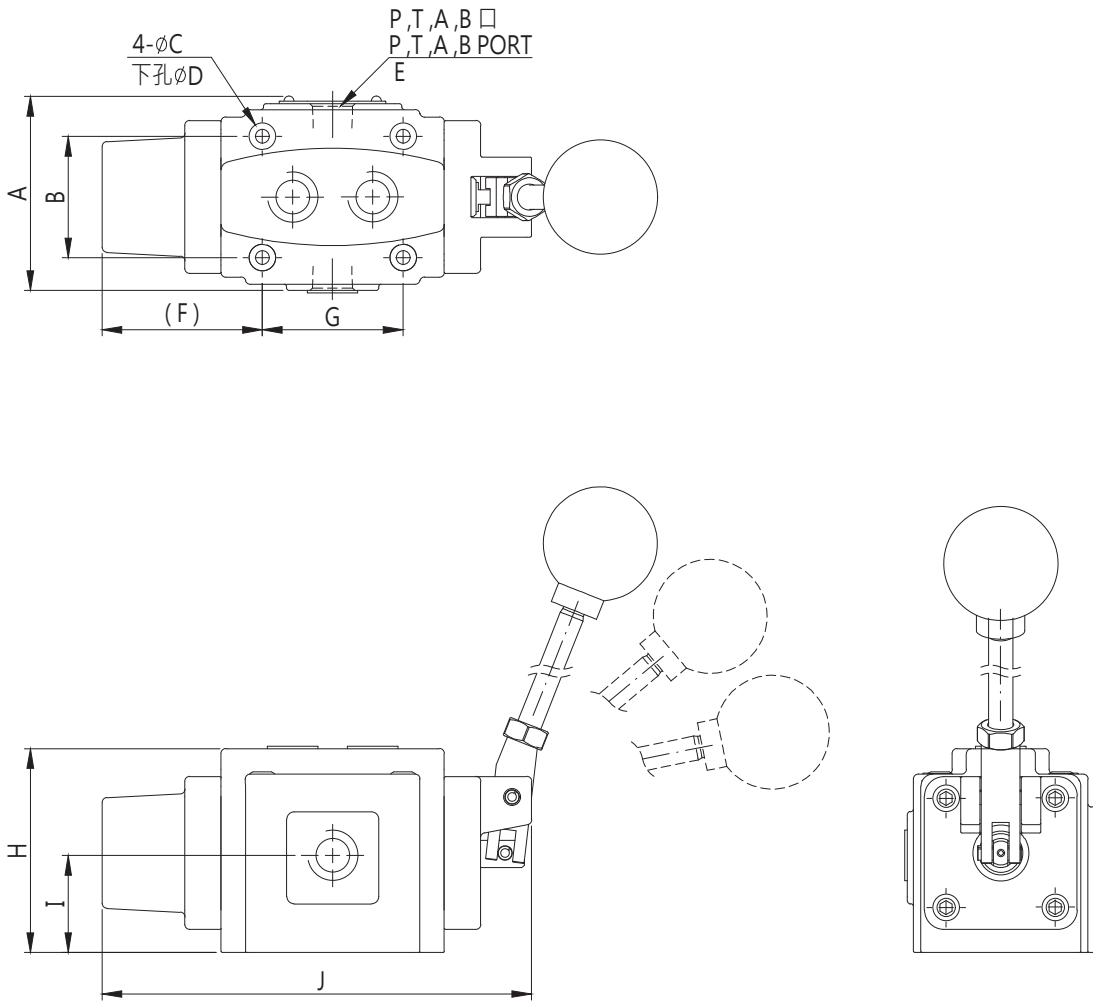

型式 MODEL	A	B	C	D	E	F	G	H	I	J
DMT-03	74.5	50	11	7	PT 3/8"	66	58	84	40	177
DMT-04	106	84	11	7	PT 1/2"	69.5	81	90	37	206
DMT-06	127	98	18	11	PT 3/4"	88	100	99	41	261
DMT-10	164	125	21	13.5	PT 1-1/4"	110.5	134	124	50	331

