

## Throttle Valve

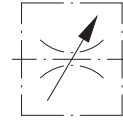

閥類型符號 SYMBOL  
SR※-※



### 規格說明

### SPECIFICATION

| 型式 MODEL                      |                                 | 最高使用壓力<br>MAX. OPERATING PRESSURE<br>kgf/cm <sup>2</sup> | 最大流量<br>MAX. FLOW<br>L/min | 重量<br>WEIGHT<br>kg |     |
|-------------------------------|---------------------------------|--|----------------------------|--------------------|-----|
| 板式安裝<br>SUB-PLATE<br>MOUNTING | 管式安裝<br>THREADED<br>CONNECTIONS |  |                            |                    |     |
| SRG-03-10                     | SRT-03-10                       | 250  | 30                         | 1.4                | 1.1 |
| SRG-06-10                     | SRT-06-10                       |  | 80                         | 2.4                | 2.8 |
| SRG-10-10                     |                                 |  | 200                        | 5.0                |     |

### 型號說明

### HOW TO ORDER

**SR G - 06 - 10**

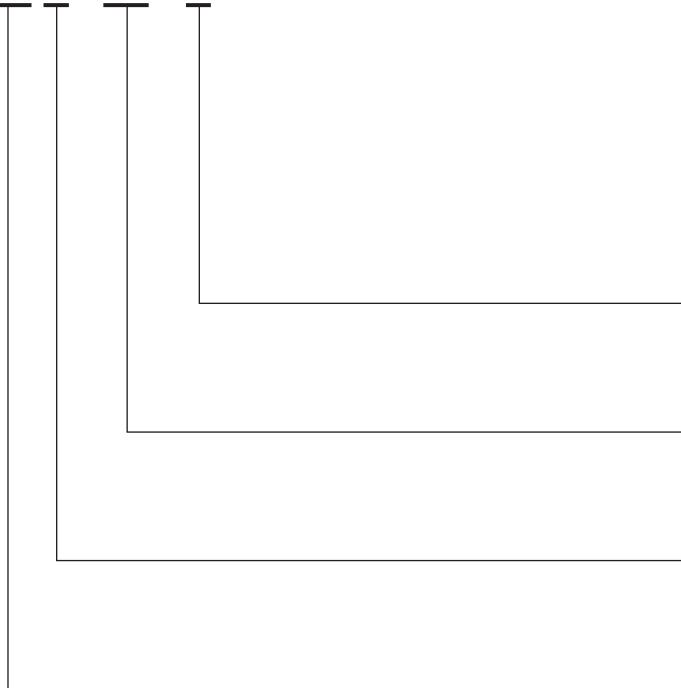

### 附屬品

### ATTACHMENT

| 型式<br>MODEL | 安裝螺絲<br>SOC HOL CAP SCREW | 安裝扭矩<br>MOUNTING TORQUE<br>N·m |
|-------------|---------------------------|--------------------------------|
| SRG-03      | M 8 x 35L...4pcs          | 31~38                          |
| SRG-06      | M10 x 45L...4pcs          | 60~74                          |
| SRG-10      | M12 x 60L...4pcs          | 104~127                        |

設計編號 DESIGN NUMBER

閥規格 VALVE SIZE  
03 : 3/8"    06 : 3/4"    10 : 1-1/4"

安裝型式 MOUNTING  
G : 板式安裝 SUB-PLATE MOUNTING  
T : 管式安裝 THREADED CONNECTIONS

系列編號 SERIES NUMBER

### 測試條件 PERFORMANCE CURVES

測試油黏度 TEST FLUID VISCOSITY : 35cSt

測試油溫度 TEST TEMPERATURE : 50°C

#### 流量與調整旋鈕特性 METERED FLOW v.s ADJ.REVOLUTIONS

#### 壓力降特性 PRESSURE DROP

##### ● SR※-03, SRC※-03

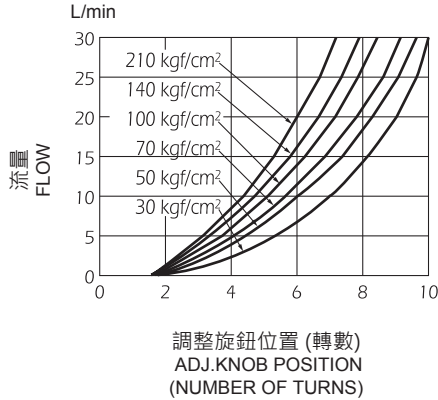

##### ● SR※-03, SRC※-03

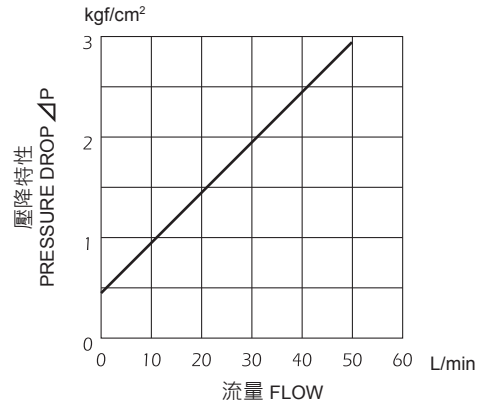

##### ● SR※-06, SRC※-06

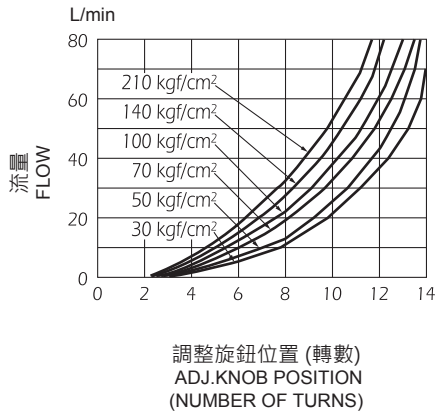

##### ● SR※-06, SRC※-06

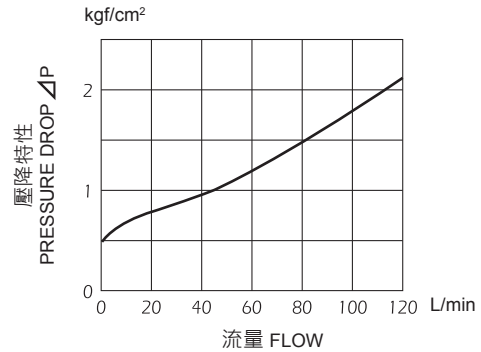

##### ● SR※-10, SRC※-10

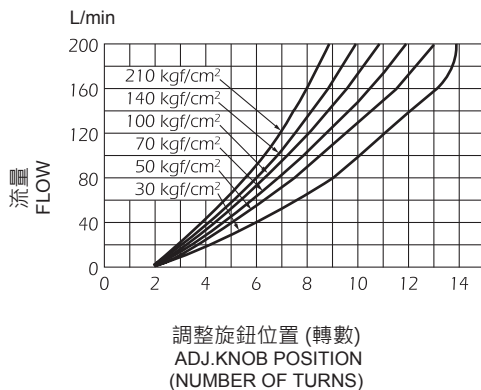

##### ● SR※-10, SRC※-10

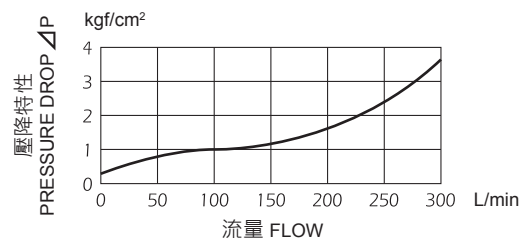

單位 UNIT : mm

**安裝尺寸** INSTALLATION DIMENSIONS

**SRG-03~10-10**

通用底板尺寸  
 APPLICATIVE  
 SUB-PLATE DIMENSIONS  
**SRG-03 ( MB - 01 - 1 )**  
**SRG-06 ( MB - 01 - 2 )**  
**SRG-10 ( MB - 01 - 3 )**  
 (詳見 E01-06 Page E01-06)

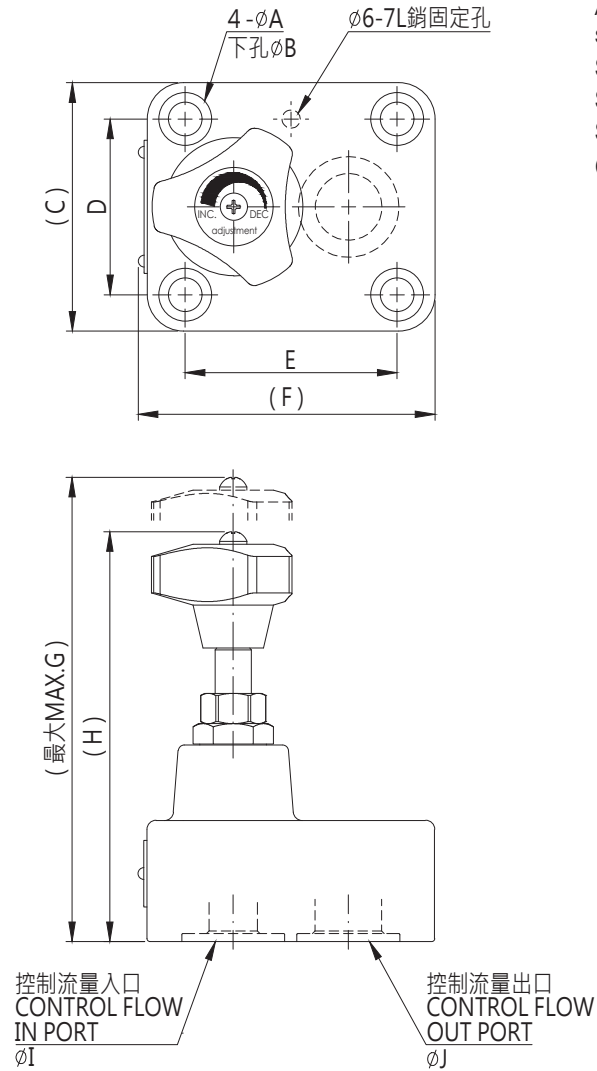

| 型式<br>MODEL | A    | B  | C     | D  | E  |
|-------------|------|----|-------|----|----|
| SRG-03-10   | 14   | 9  | 61    | 40 | 60 |
| SRG-06-10   | 17.5 | 11 | 82    | 58 | 70 |
| SRG-10-10   | 20   | 13 | 101.5 | 72 | 92 |

| 型式<br>MODEL | F   | G   | H     | I  | J  |
|-------------|-----|-----|-------|----|----|
| SRG-03-10   | 83  | 132 | 111.5 | 14 | 15 |
| SRG-06-10   | 98  | 136 | 121   | 16 | 22 |
| SRG-10-10   | 119 | 164 | 143.5 | 25 | 30 |

單位 UNIT : mm

#### 安裝尺寸 INSTALLATION DIMENSIONS

### SRT-03,06-10

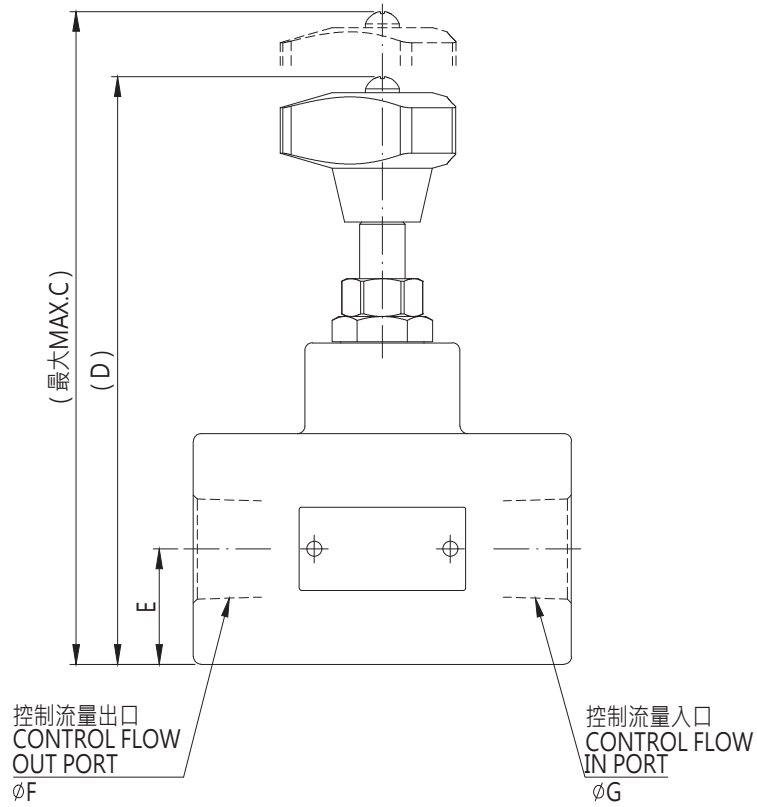
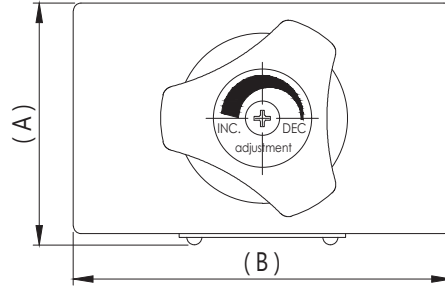

| 型式<br>MODEL | A  | B   | C   | D     | E    | F       | G       |
|-------------|----|-----|-----|-------|------|---------|---------|
| SRT-03-10   | 44 | 70  | 146 | 125.5 | 22   | PT 3/8" | PT 3/8" |
| SRT-06-10   | 64 | 100 | 156 | 142   | 30.5 | PT 3/4" | PT 3/4" |