

Throttle And Check Valve

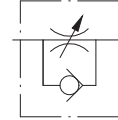

閥類型符號 SYMBOL
SRC※-※



規格說明

SPECIFICATION

型式 MODEL		最高使用壓力 MAX. OPERATING PRESSURE kgf/cm ²	最大流量 MAX. FLOW L/min	重量 WEIGHT kg	
板式安裝 SUB-PLATE MOUNTING	管式安裝 THREADED CONNECTIONS				
SRCG-03-10	SRCT-03-10	250	30	2.3	1.5
SRCT-04-10			50	1.5	
SRCG-06-10	SRCT-06-10		80	4.3	3.8
SRCG-10-10	SRCT-10-10		200	8.6	7.3

型號說明

HOW TO ORDER

SRC G - 06 - 10

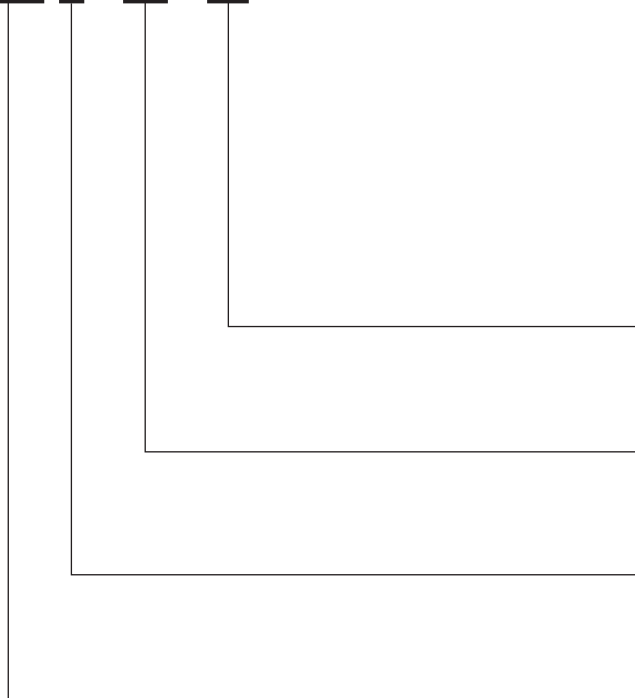

附屬品

ATTACHMENT

型式 MODEL	安裝螺絲 SOC HOL CAP SCREW	安裝扭矩 MOUNTING TORQUE N·m
SRCG-03-10	M8 x 60L.....4pcs	31~38
SRCG-06-10	M10 x 75L.....4pcs	60~74
SRCG-10-10	M12 x 100L...4pcs	104~127

設計編號 DESIGN NUMBER

閥規格 VALVE SIZE

03 : 3/8" 04 : 1/2" 06 : 3/4" 10 : 1-1/4"

安裝型式 MOUNTING

G : 板式安裝 SUB-PLATE MOUNTING

T : 管式安裝 THREADED CONNECTIONS

系列編號 SERIES NUMBER

單位 UNIT : mm

安裝尺寸 INSTALLATION DIMENSIONS

SRCG-03~10

通用底板尺寸

APPLICATIVE

SUB-PLATE DIMENSIONS

SRCG-03 (MB - 01 - 1)

SRCG-06 (MB - 01 - 2)

SRCG-10 (MB - 01 - 3)

(詳見 E01-06 Page E01-06)

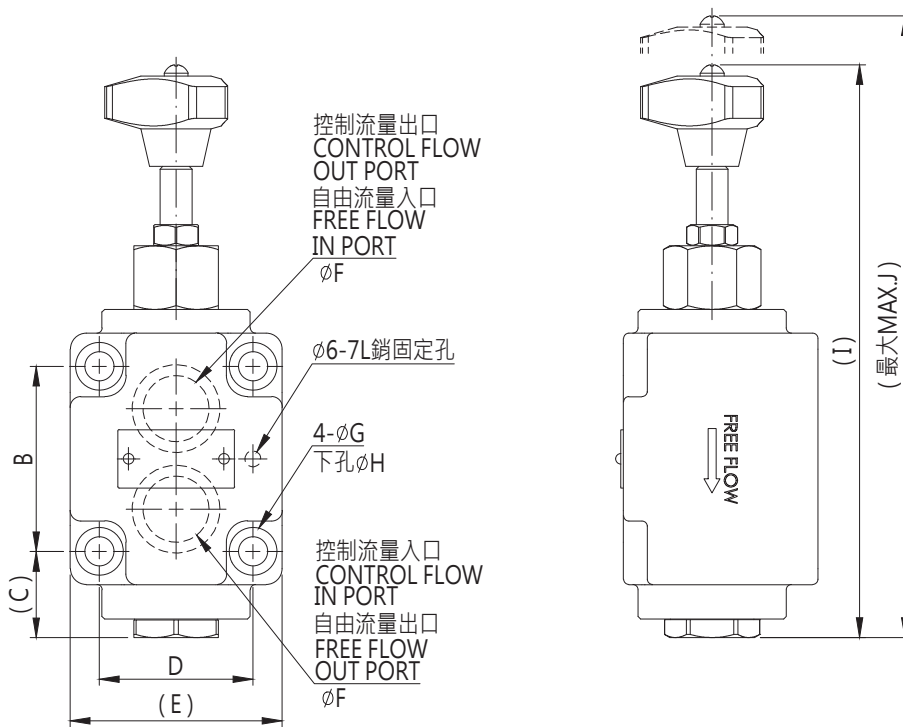
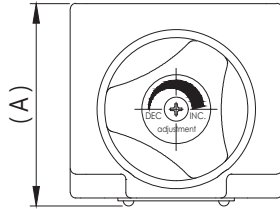

型式 MODEL	A	B	C	D	E
SRCG-03	63	60	30	40	61
SRCG-06	76.5	70	32.5	58	80
SRCG-10	98	92	32.8	72	100

型式 MODEL	F	G	H	I	J
SRCG-03	15	14	9	166.5	180
SRCG-06	25	17.5	11	194.5	216.5
SRCG-10	30	20	13	220	245

單位 UNIT : mm

安裝尺寸 INSTALLATION DIMENSIONS

SRCT-03~10

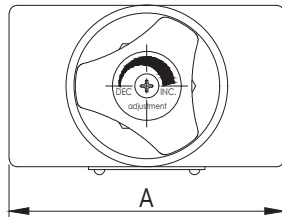

SRCT-10調整螺桿示意圖
< 標準型(內六角) >

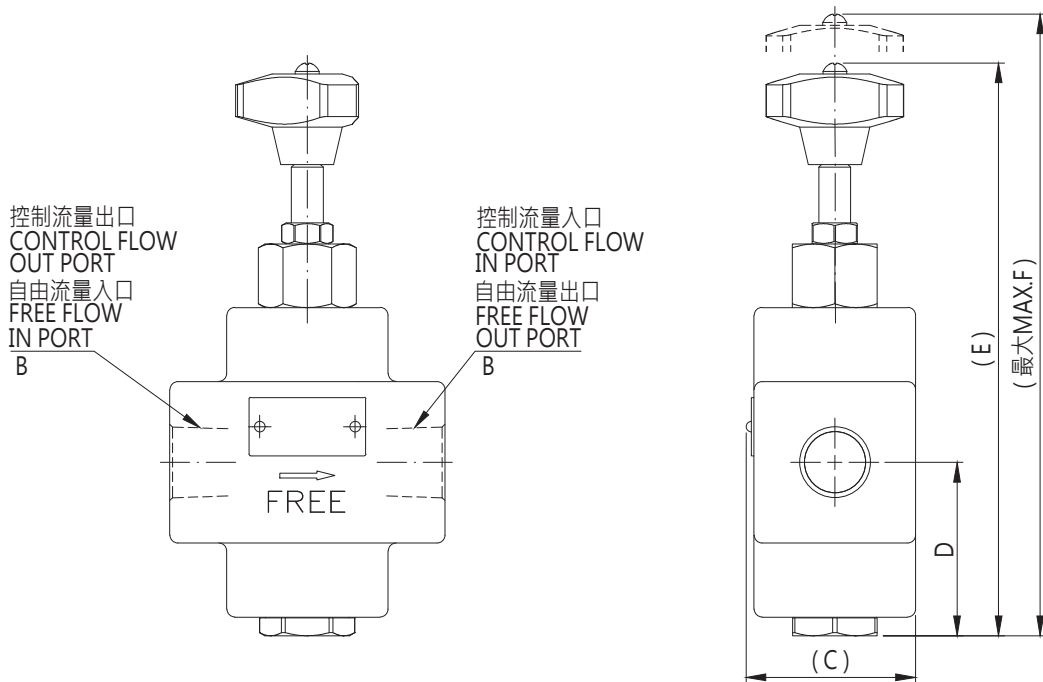
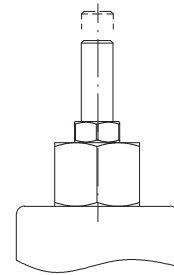

型式 MODEL	A	B	C	D	E	F
SRCT-03	68	PT 3/8"	44	60	166.5	180
SRCT-04	68	PT 1/2"	44	60	166.5	180
SRCT-06	104	PT 3/4"	64	65.5	194.5	216.5
SRCT-10	132	PT 1-1/4"	81	77	209	227