

Solenoid Operated Flow Control Valve

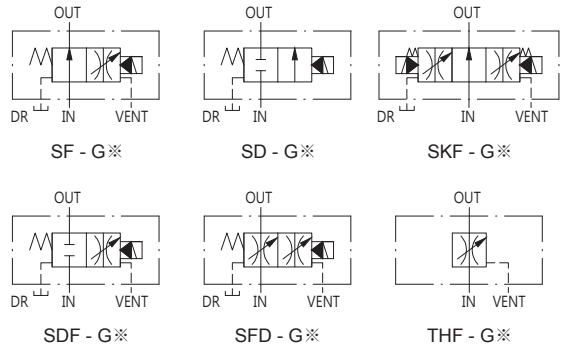

閥類型符號 SYMBOL



規格說明

SPECIFICATION

型式 MODEL	最高使用壓力 MAX. OPERATING PRESSURE (kgf/cm ²)	最大流量 MAX. FLOW L/min	導閥型式 PILOT VALVE TYPE	重量 (不含電磁閥) WEIGHT(NO CONTAIN SOLENOID VALVE) (kg)	
SF-G03	250	60	4WE-6Y	3.0	
SDF-G03			4WE-6D	3.0	
SD-G03			4WE-6D	3.2	
SFD-G03			4WE-6Y	2.2	
SKF-G03			4WE-6J	3.2	
THF-G03				3.0	
SF-G06		120	4WE-6Y	5.6	
SDF-G06			4WE-6D	5.6	
SD-G06			4WE-6D	5.1	
SFD-G06			4WE-6Y	6.0	
SKF-G06			4WE-6J	7.0	
THF-G06				5.5	
SF-G10		240	240	4WE-6Y	8.7
SDF-G10				4WE-6D	8.7
SD-G10	4WE-6D			8.0	
SFD-G10	4WE-6Y			9.3	

型號說明

HOW TO ORDER

SF - G 06 - E T V - W220/50 - 20 - 40

電磁閥型式 SOLENOID TYPE

接線方式 WIRING

10 : 帶燈的集中連接盒

WITH LAMP CENTRAL CONNECTION

20 : 插入式接頭帶密封套 PLUG-IN CONNECTION

線圈電壓 COIL VOLTAGE

G12 : 12V DC

G24 : 24V DC

W110 : 110/50/60Hz

W220 : 220/50/60Hz

V : 壓力追蹤 PRESSURE TRACK

T : 外部洩油 EXTERNAL DRAIN

E : 外部引導 EXTERNAL PILOT

閥規格 VALVE SIZE

03 : 3/8"

06 : 3/4"

10 : 1-1/4"

安裝型式 MOUNTING

G : 板式安裝 SUBPLATE MOUNTED

系列編號 SERIES NUMBER

附屬品 ATTACHMENT

型式 MODEL	安裝螺絲 SOC HOL CAP SCREW	安裝扭矩 MOUNTING TORQUE N·m	4WE-06電磁閥重量 SOLENOID WEIGHT (kg)	
			AC	DC
G-03	M6 X 65L.....4pcs	12~15		
G-06	M10 X 45L...4pcs	60~74	帶1個電磁鐵 Single coil	1.6 1.7
G-10	M12 X 55L...4pcs	104~127	帶2個電磁鐵 Two coils	2.1 2.1

測試條件 PERFORMANCE CURVES

測試油黏度 TEST FLUID VISCOSITY : 35cSt

測試油溫度 TEST TEMPERATURE : 50°C

壓力、流量特性 PRESSURE DROP FOR FREE FLOW

● G03

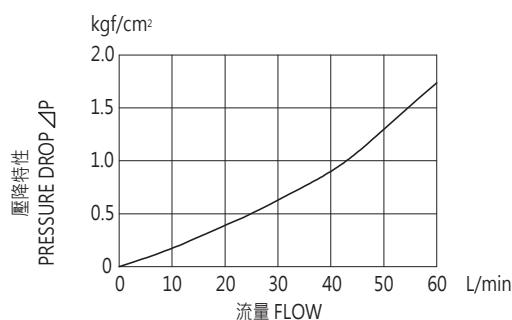

● G06

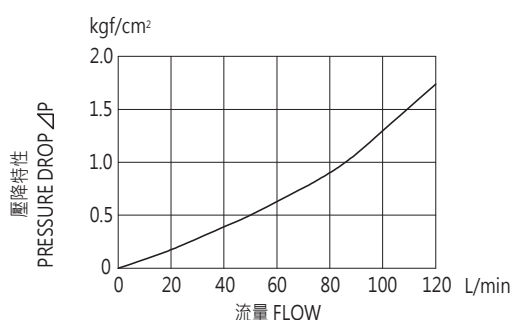

● G10

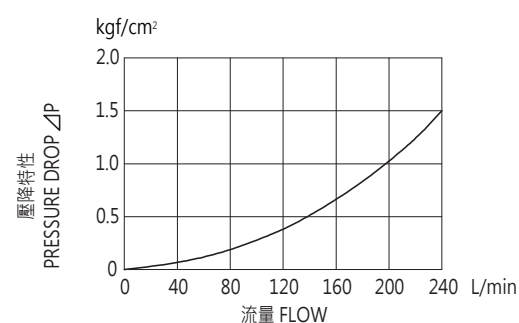

單位 UNIT : mm

安裝尺寸 INSTALLATION DIMENSIONS

SF-G03~10..DC

通用底板尺寸 APPLICATIVE SUB-PLATE DIMENSIONS

SF-G03 (MB - 02 - 1)

SF-G06 (MB - 02 - 2)

SF-G10 (MB - 02 - 3)

(詳見 E01-07 Page E01-07)

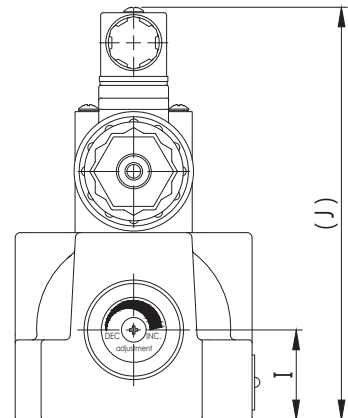
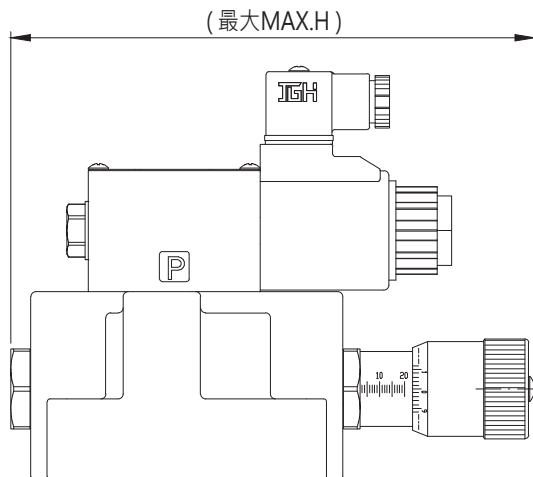
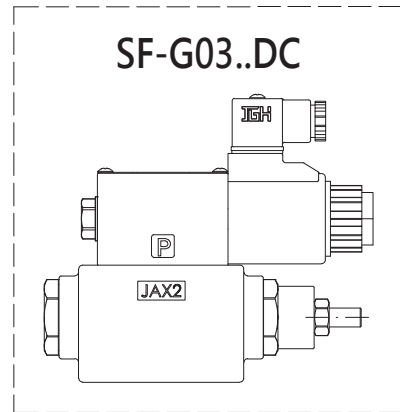
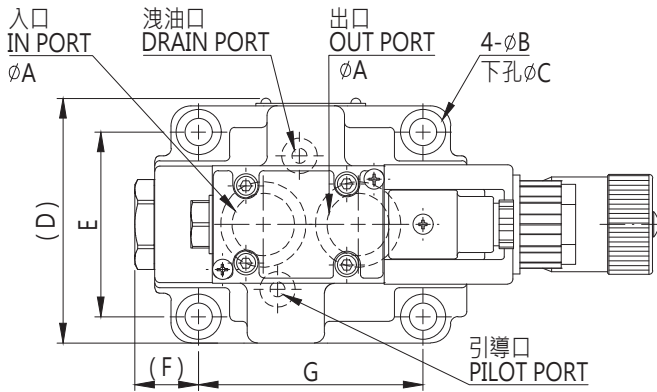

型式 MODEL	A	B	C	D	E
SF-G03..DC	15	11	7	69.5	40
SF-G06..DC	25	17.5	11	98	74
SF-G10..DC	30	20	13	119	86

型式 MODEL	F	G	H	I	J
SF-G03..DC	31.8	60	174	34.3	152.5
SF-G06..DC	25.5	90	210	36	165.5
SF-G10..DC	29	112	246.5	40.5	175.5

單位 UNIT : mm

安裝尺寸 INSTALLATION DIMENSIONS

SDF-G03~10..DC

通用底板尺寸 APPLICATIVE SUB-PLATE DIMENSIONS

SDF-G03 (MB - 02 - 1)

SDF-G06 (MB - 02 - 2)

SDF-G10 (MB - 02 - 3)

(詳見 E01-07 Page E01-07)

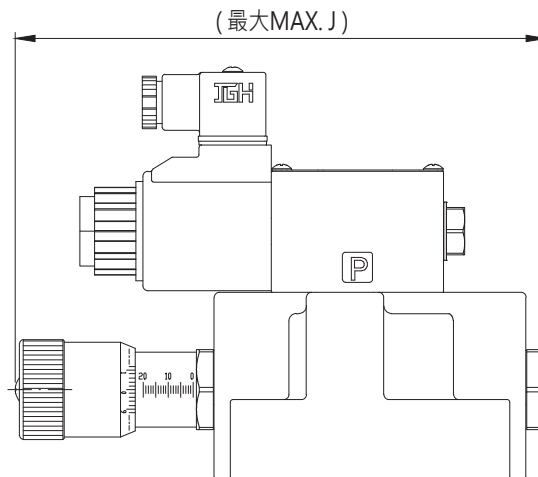
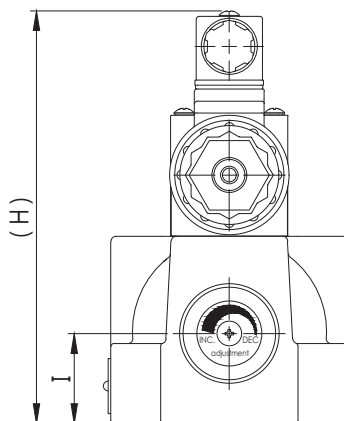
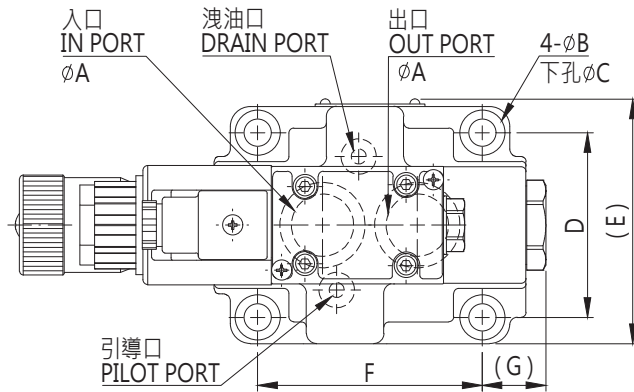
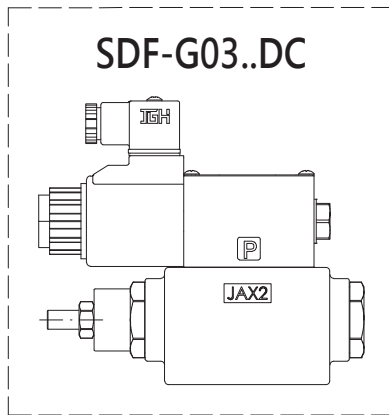

型式 MODEL	A	B	C	D	E
SDF-G03..DC	15	11	7	40	69.5
SDF-G06..DC	25	17.5	11	74	98
SDF-G10..DC	30	20	13	86	119

型式 MODEL	F	G	H	I	J
SDF-G03..DC	60	31.8	152.5	34.3	172.5
SDF-G06..DC	90	25.5	165.5	36	213
SDF-G10..DC	112	29	175.5	40.5	246.5

單位 UNIT : mm

安裝尺寸 INSTALLATION DIMENSIONS

SD-G03~10..DC

通用底板尺寸

APPLICATIVE

SUB-PLATE DIMENSIONS

SD-G03 (MB - 02 - 1)

SD-G06 (MB - 02 - 2)

SD-G10 (MB - 02 - 3)

(詳見 E01-07 Page E01-07)

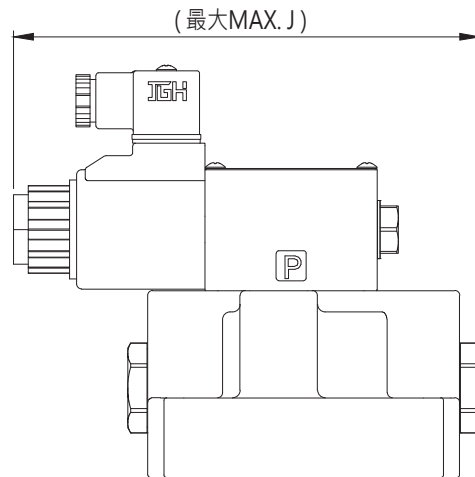
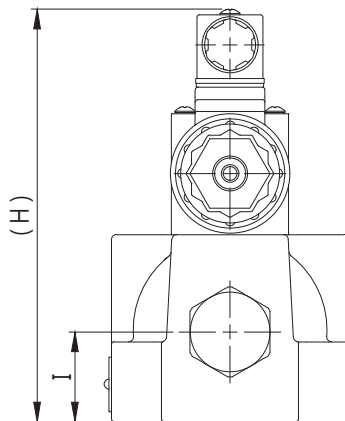
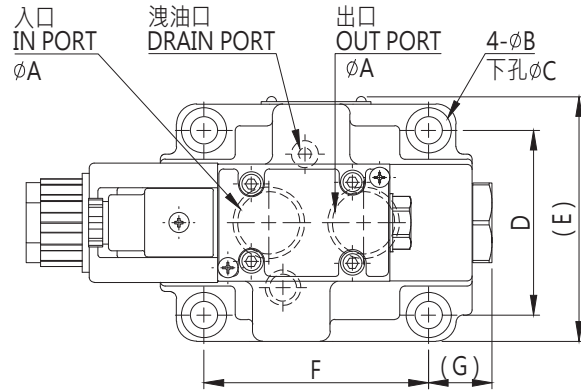

型式 MODEL	A	B	C	D	E
SD-G03..DC	15	11	7	40	69.5
SD-G06..DC	25	17.5	11	74	98
SD-G10..DC	30	20	13	86	119

型式 MODEL	F	G	H	I	J
SD-G03..DC	60	31.8	152.5	34.3	172.5
SD-G06..DC	90	25.5	165.5	36	187
SD-G10..DC	112	29	175.5	40.5	207

單位 UNIT : mm

安裝尺寸 INSTALLATION DIMENSIONS

SFD-G03~10..DC

通用底板尺寸 APPLICATIVE SUB-PLATE DIMENSIONS

SFD-G03 (MB - 02 - 1)

SFD-G06 (MB - 02 - 2)

SFD-G10 (MB - 02 - 3)

(詳見 E01-07 Page E01-07)

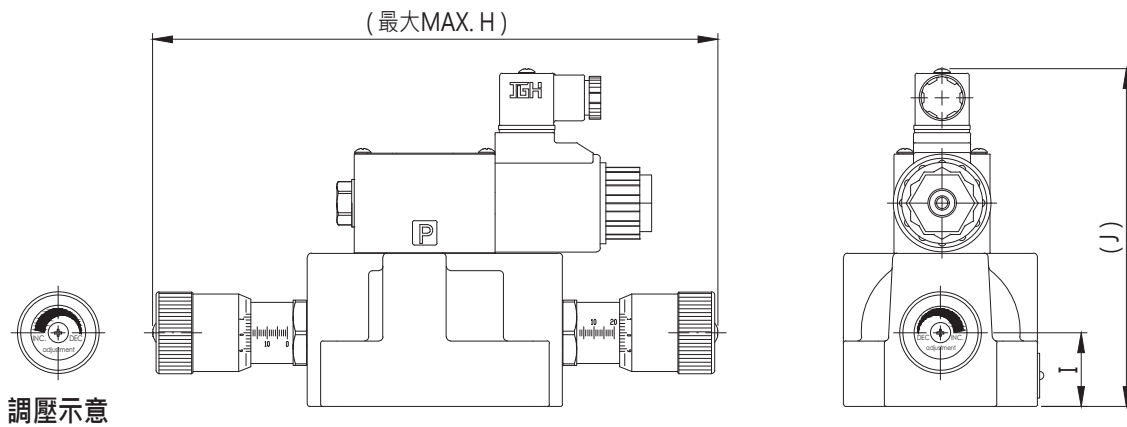
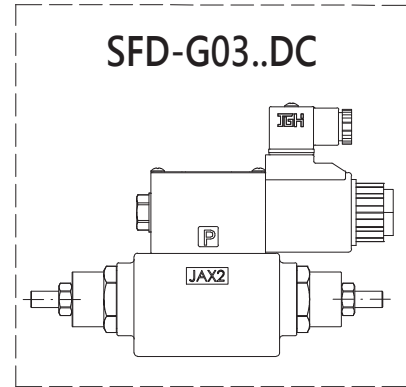
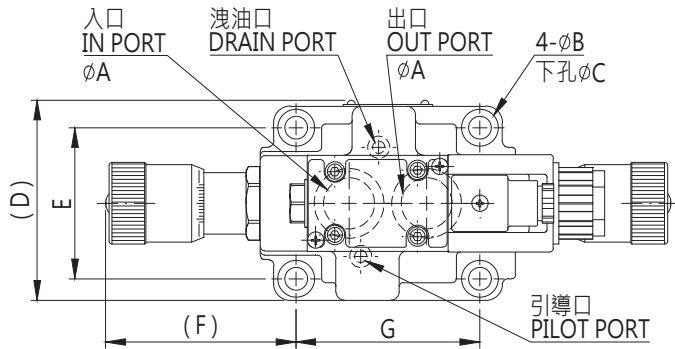

型式 MODEL	A	B	C	D	E
SFD-G03..DC	15	11	7	69.5	40
SFD-G06..DC	25	17.5	11	98	74
SFD-G10..DC	30	20	13	119	86

型式 MODEL	F	G	H	I	J
SFD-G03..DC	76	60	218	34.3	152.5
SFD-G06..DC	93.5	90	277	36	165.5
SFD-G10..DC	105.5	112	323	40.5	175.5

單位 UNIT : mm

安裝尺寸 INSTALLATION DIMENSIONS

SKF-G03,06..DC

通用底板尺寸 APPLICATIVE SUB-PLATE DIMENSIONS

SKF-G03 (MB - 02 - 1)

SKF-G06 (MB - 02 - 2)

(詳見 E01-07 Page E01-07)

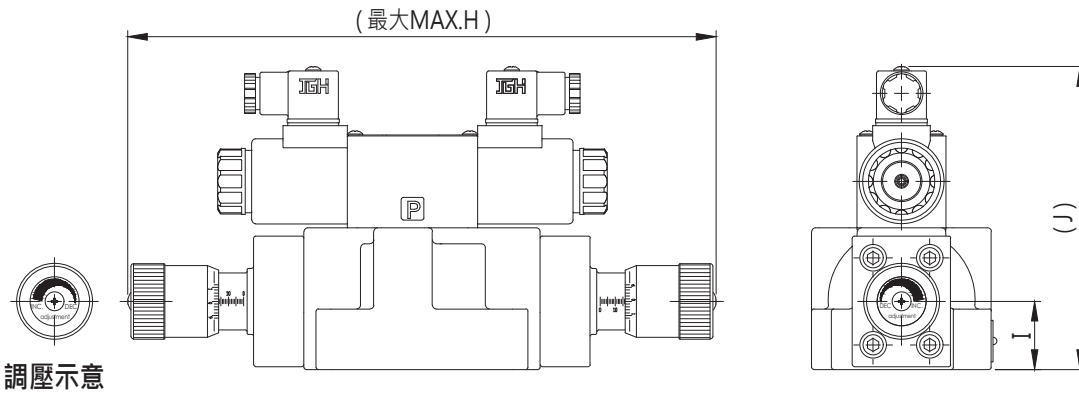
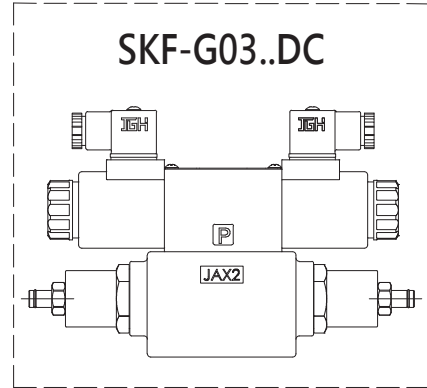
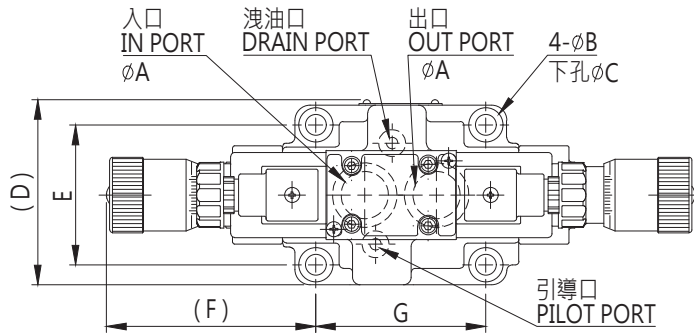

型式 MODEL	A	B	C	D	E
SKF-G03..DC	15	11	7	69.5	40
SKF-G06..DC	25	17.5	11	98	74

型式 MODEL	F	G	H	I	J
SKF-G03..DC	83.5	60	227	34.3	152.5
SKF-G06..DC	111	90	311.5	36	165.5

單位 UNIT : mm

安裝尺寸 INSTALLATION DIMENSIONS

THF-G03, 06

通用底板尺寸 APPLICATIVE SUB-PLATE DIMENSIONS

THF-G03 (MB - 02 - 1)

THF-G06 (MB - 02 - 2)

(詳見 E01-07 Page E01-07)

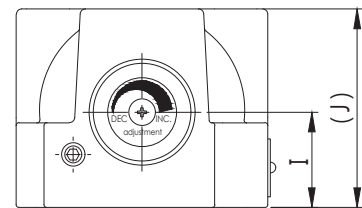
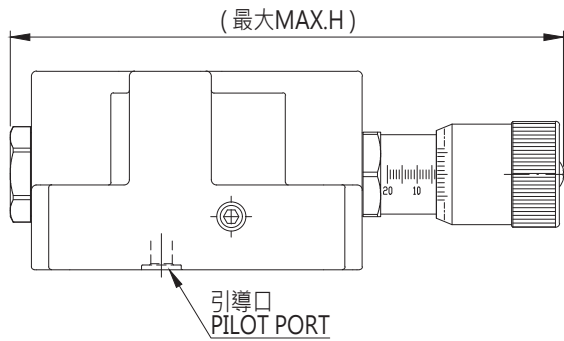
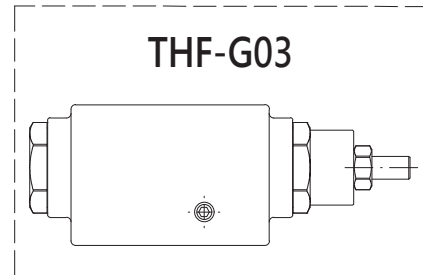
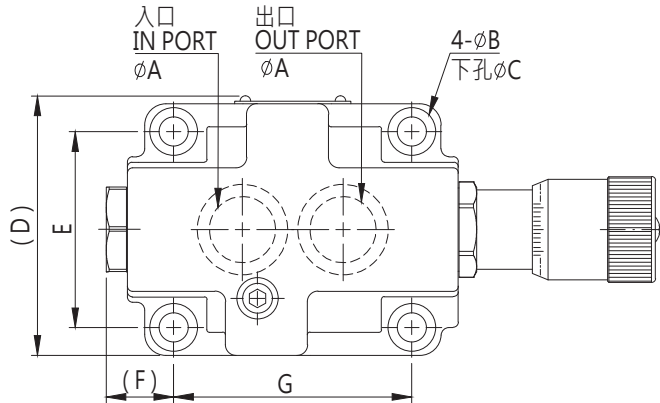

型式 MODEL	A	B	C	D	E
THF-G03	15	11	7	69.5	40
THF-G06	25	17.5	11	98	74

型式 MODEL	F	G	H	I	J
THF-G03	31.8	60	168	34.3	62
THF-G06	25.5	90	210	36	75